

FINAL TECHNICAL REPORT (PUBLISHABLE VERSION)

CONTRACT N°: G4RD-CT-2000-00192

PROJECT N°: GRD1-1999-10014

ACRONYM: CRYOPLANE

TITLE: Liquid Hydrogen Fuelled Aircraft – System Analysis

PROJECT CO-ORDINATOR : Airbus Deutschland GmbH

PARTNERS :

Airbus Deutschland GmbH (Germany); Advanced Products NV (Belgium); Airbus France (France)
Alenia Finmeccanica S.p.A (Italy); Aristotle University of Thessaloniki, Lab. of Heat Transfer &
Environmental Eng. (Greece); Aristotle University of Thessaloniki, Laboratory of Atmospheric Physics
(Greece); DIEHL Avionik Systeme GmbH (Germany); Airbus UK (UK); Bundesanstalt für
Materialforschung und -prüfung (Germany); Centro Italiano Ricerche Aerospaziali (CIRA) (Italy); Airbus
España (CASA) (Spain); Cranfield University, College of Aeronautics (UK); Cranfield University, School of
Mechanical Engineering (UK); Deutsches Zentrum für Luft-und Raumfahrt e.V. (Germany); Fairchild
Dornier GmbH (Germany); ET GmbH Hydrogen Technology and Test Center (Germany); European
Commission – Joint Research Centre Ispra ISIS (Italy); Fachhochschule Aachen (Germany); FOI Swedish
Defense Research Agency (Sweden); Fraunhofer Gesellschaft e.V, IfU (Germany); Grimm Aerosol
Technik GmbH & Co KG (Germany); Air Liquide (France); Linde AG (Germany); Universitetet i Oslo
(Norway); Secondo Mona S.p.A. (Italy); Snecma, SEP Division (France); THALES Avionics SA (France);
Shell Hydrogen B.V. (Netherlands); MI Developments Austria AG&Co.KG (Austria); Technische
Universität Berlin (Germany); Technische Universität Hamburg-Harburg (Germany); Technische
Universität München (Germany); Techspace Aero (Belgium), Delft University of Technology
(Netherlands); Universidad Politecnica Madrid (Spain); MTU Aero Engines GmbH (Germany)

REPORTING PERIOD: FROM 1st April , 2000 TO 31st May 2002

PROJECT START DATE : 1.April 2000

DURATION : 26 months

Date of issue of this report : 24. September 2003



**Project funded by the European Community
under the 'Competitive and Sustainable
Growth' Programme (1998-2002)**

**Final Technical Report
CRYOPLANE
System Analysis
(Publishable Version)**

1 Table of Contents

1 Table of Contents

2 Executive Publishable Summary

3 Objectives of the Project

4 Scientific and Technical Description of the Results

4 Technical Description

4.1 Work Package 1 Project Management

4.2 Work Package 2 Aircraft Configuration

4.3 Work Package 3 Systems and Components

4.4 Work Package 4 Propulsion

4.5 Work Package 5 Safety

4.6 Work Package 6 Environmental Compatibility

4.7 Work Package 7 Fuel Sources and Infrastructure

4.8 Work Package 8 Transition Scenarios

4.9 Work Package 9 Trade-off: Slush

4.10 Overall Conclusions

5 Results and Conclusions

6 Acknowledgements

7 Glossary

8 References

Final Technical Report CRYOPLANE System Analysis (Publishable Version)

2 Executive Publishable Summary

Objectives

The objectives of this were to develop a conceptual basis for applicability, safety, and full environmental compatibility, and to investigate medium/long term scenarios for a smooth transition from kerosene to hydrogen in aviation. This system analysis covers all relevant technical, environmental, societal and strategic aspects providing a sound basis for initiating larger scale activities preparing for the development and introduction of Liquid Hydrogen as an aviation fuel.

Important results and achievements

- In order to analyse the potential H2 as an alternative fuel from the aircraft industrial side the scope of this project is related to the range of aircraft categories in commercial operation.
- As a result of this project overall aircraft configurations have been identified which meet the requirements of efficient and safe operation in aircraft categories, from “Business Jets” to “Very Large Long Range Aircraft” (A380 class). Their performance has been analysed and compared to current aircraft.
- Following features resulted from comprehensive calculations and parametric studies for the above listed range of aircraft categories.
 - Due to the bigger wetted surface of the aircraft due to H2 storage in pressure vessels the energy consumption would increase by 9% to 14%.
 - The OWE (Operating Weight Empty) may increase by roughly 23% by having additional tank structure,
 - while the difference of the MTOW (Maximum Take-Off Weight) will vary between plus 4,4% to minus 14,8% depending on the aircraft configuration and mission.

All this will result into an increase of the operating costs by 4% to 5% caused by fuel only.

- Various unconventional configurations have been assessed. An advantage of the selected configurations could not be identified.
- Based on an overall architecture for the fuel system, which was adapted to alternative tank arrangements required for different aircraft categories, the technical feasibility and availability of suitable components has been assessed. Known design principles can be applied, but detail R&T work will be necessary to meet aviation specific requirements. In general there are components of two major sources of applications available. While the components of industrial use are too heavy the components for aerospace use are only built for missions of several minutes.

**Final Technical Report
CRYOPLANE
System Analysis
(Publishable Version)**

- Detailed analysis of “conventional“ engines has confirmed that a hydrogen-fuelled engine will be as efficient as a kerosene engine in terms of energy consumed.
- System analysis has shown that the conversion of conventional turbo engines can be done. The fuel supply and the injection system have to be redesigned. The control system may be adapted on the basis of existing design.
- A heat exchanger was identified as one novel feature of the fuel supply system. It is needed to heat up the liquid hydrogen to a temperature, which is suitable to the injection into the combustion chamber. Different design principles have been assessed. The result has confirmed the feasibility, but further research is needed for validation of the design itself and its implementation into the power plant.
- Substantial improvements in NO_x emissions have been quantified on the basis of experimental data. No difference in noise emissions has been found. Small but not negligible benefits have been found for unconventional engine configurations, utilizing the liquid hydrogen’s cooling capacity.
- Safety aspects specific to aviation have been assessed; coming to the overall conclusion that hydrogen fuelled aircraft will not be less safe than conventionally fuelled aircraft. Requirements and regulations for ground handling and servicing have to be reviewed and adapted. Airworthiness requirements may be amended according to the specific behaviour of LH₂ and technical design solutions.
- All kind of accidental incidents and results of emergency landings have been identified and analysed. Technical design solutions and/or possible changes of operating procedures have been identified.
- Conservative life cycle analysis, based on the data taken from the detailed analysis of the different production, transportation, storage and consumption methods (well to wheel) of H₂ and kerosene performed and compared.
- With respect to environmental compatibility, great benefits have been identified looking at the long-term benefits of H₂ as an alternative fuel. Even if the production of H₂ will start by reforming natural gas producing CO₂ as a by-product. In addition this CO₂ may be collected by a sequestering process and stored as shown in other projects. The replacement of the steam reforming process by H₂ production by using renewable energy will be the potential of this technology.
- According to extensive computer simulations, contrails produced by hydrogen-fuelled aircraft will contribute less to anthropogenic greenhouse effect compared to the conventional case. The H₂ fuelled main engines may produce 2,6 times more H₂O as kerosene fuelled engines. H₂O is a greenhouse gas, which will remain only very short time, about half a year, in the upper atmosphere whereas CO₂, which is emitted by a kerosene engine, remains about 100 years in place.

**Final Technical Report
CRYOPLANE
System Analysis
(Publishable Version)**

- Global scenarios for a soft transition to the new fuel have been quantified and checked for practicality in detail by considering Sweden as the leading region during transition to hydrogen.
- Hydrogen produced on the basis of renewable energy has been confirmed as offering a chance of continuing long-term growth of aviation without damaging the atmosphere. No showstopper could be identified.

Summary

This CRYOPLANE System Analysis has shown that hydrogen could be a suitable alternative fuel for the future aviation. Nevertheless, due to the missing materials, parts, components and engines further R&D work has to be performed until hydrogen can be used as an aircraft fuel. According to estimations made during this project the earliest implementation of this technology could be expected in 15 to 20 years, provided that research work will continue on an adequate level.

From the operating cost point of view hydrogen remains unattractive under today's condition, with kerosene is much cheaper as hydrogen and production/infrastructure is completely missing.

Assessments based on conservative calculations and today's understanding have confirmed that the use of hydrogen would reduce aircraft emissions to a minimum. It needs to be validated that the water emission of hydrogen-fuelled aircraft has low impact to the atmosphere as predicted.

**Final Technical Report
CRYOPLANE
System Analysis
(Publishable Version)**

3 Objectives of the Project.

Air traffic has experienced strong growth over a long time, and it is predicted that such growth will continue at rates of 4 – 5 % p.a. over the next decades. Current traffic losses in the aftermath of September 11th 2001 are expected to be only temporary. Assuming continuing worldwide economic growth, saturation of air traffic is not yet in sight. For the aircraft manufacturers, this is a highly welcome prospect, because only one third of their production is for replacement of old aircraft, two thirds of the production serves the needs of traffic growth.

On the other hand, it is generally accepted that the emission of greenhouse gases, most notably of long-living carbon dioxide (CO₂), resulting from men's activities, cannot be allowed to continue increasing if adverse global climate change is to be avoided.

Air traffic today contributes only some 3% to the anthropogenic greenhouse effect. Advances in aeronautical engineering have led and will lead to significant improvement in energy efficiency of transport aircraft. But there is no realistic prospect that such gains in efficiency will be sufficient to compensate for expected traffic growth as far as CO₂ emissions are concerned. Nor is it likely that aviation will be accorded a privileged exemption from the general need to reduce CO₂ emissions.

Whatever the detailed measures applied by the governments to force reduction of emissions will be, aviation runs the risk to be confronted with the choice between painful loss of business or change to some new technology avoiding greenhouse gas emissions. To prepare for such a situation, the principal possibilities for such technology's should be identified and understood, and the technological basis should be established allowing short/medium term change to the new technology.

Liquid hydrogen, produced on the basis of renewable energy (or – for some transition period! – from fossil sources with CO₂ sequestering), is the only known new fuel meeting the requirements.

**Final Technical Report
CRYOPLANE
System Analysis
(Publishable Version)**

4 Scientific and Technical Description of the Results

4. Technical Description

4.1 Work Package 1 Project Management

4.2 Work Package 2 Aircraft Configuration

Objectives

The objective of WP2 of this project was to identify aircraft configurations, which meet the requirements of efficient and safe operation in all aircraft categories, from “Business Jets” to “Very Large Long Range Aircraft”. Their performance and DOC should be analysed and compared to conventional aircraft.

Based on data coming from the other work packages configurations of the selected aircraft categories have been developed. Aircraft performances have been calculated and compared with conventional aircraft.

The work on Aircraft configurations WP2 was separated into two main groups of tasks; the conventional and unconventional configurations.

Conventional aircraft configurations have been evaluated for those categories, which were selected before, whereas unconventional categories were developed in a more general way.

Final Technical Report CRYOPLANE System Analysis (Publishable Version)

Conventional Configurations

For a selection of transport aircraft, ranging from regional turboprops to very large, long-range jet aircraft like the A380 (Figure 1), a comparison has been made between kerosene and LH2 fuelled versions. The tank layout turned out to be the driver for the configurational design as LH2 requires 4 times more storage volume than kerosene for the same energy content and additionally must be stored pressurized. Calculations on the weight for the LH2 tank structure have shown that the use of wing tanks would be too heavy (read details in section S/M Range A/C). The optimal choice for the tank layout depends on the aircraft category. For seven categories of aircraft, three basic tank layouts are proposed.

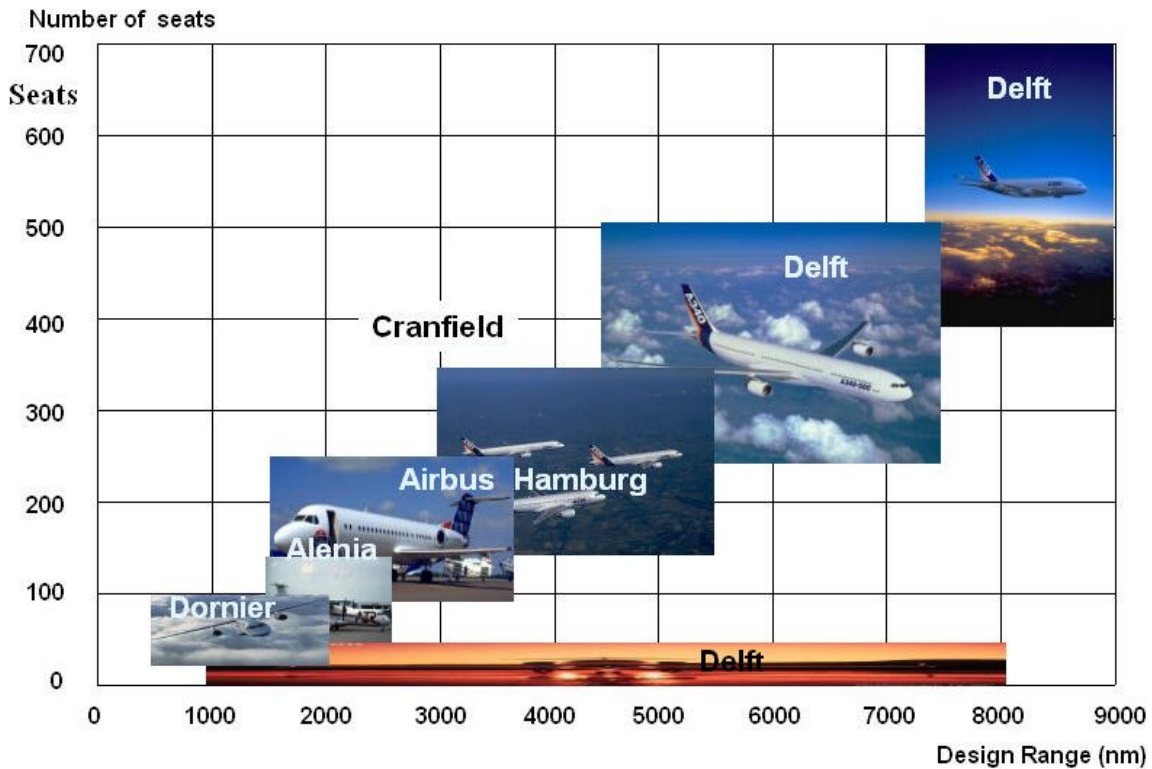

Figure 1: Range of Aircraft Categories, which have been subject of this Project.

For “Small Regional Aircraft” and “Business Aircraft” tanks are arranged in the fuselage aft of the rear pressure bulkhead only. For “Regional aircraft up to 100 seats” (turboprop as well as jet) and “Short/Medium Range Aircraft” tanks are arranged behind the aft pressure bulkhead and on top of the fuselage. For “Long Range Aircraft” and “Very Large Long Range Aircraft” (VLLR) tanks are proposed in the fuselage aft of the rear pressure bulkhead and between the cabin and the cockpit.

Final Technical Report CRYOPLANE System Analysis (Publishable Version)

Small Regional Aircraft and Business Aircraft

The simplest solution, the tank behind the aft pressure bulkhead, is only feasible from a centre of gravity location consideration when the fuel weight fraction is small. Hence it is applicable only to the “Small Regional Aircraft”. Because of the similarity in size this concept was applied on “Business Aircraft” as well. To reduce the impact of the single tank on the centre of gravity, a wider fuselage was adapted than usual. An exploratory study revealed



Figure 2: Small Regional Aircraft

yet an excessive centre of gravity travel, probably requiring a combination of fly-by-wire and a very large horizontal tail, or operational restrictions to the centre of gravity. As a result, the aircraft will suffer from increased trim drag and reduced maximum lift.



Figure 3: Business Aircraft

Regional 100-seater Aircraft.

For larger fuel fractions and thus range, the fuel in the aft tank must be balanced by a more forward tank. For the “Regional aircraft up to 100 seats” (turbo-prop and turbo-jet) and “Short/Medium Range Aircraft” the fuselage diameter is too small to enable a

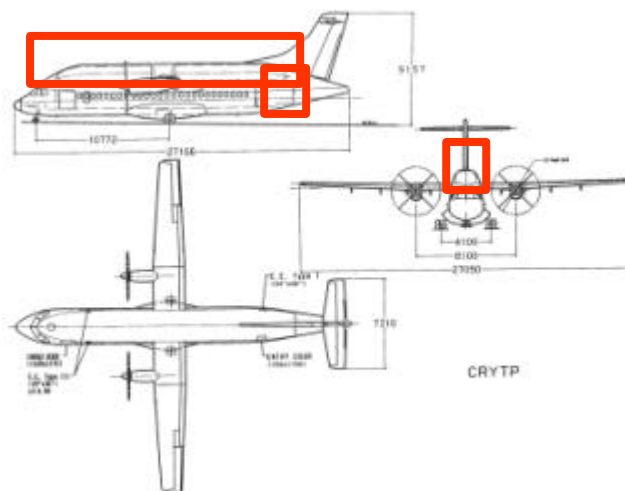

Figure 4: Regional Turboprop Aircraft

catwalk parallel to and beside the forward tank, to serve as the cockpit-cabin connection. This forces the tank on top of the fuselage, thereby creating a weight and profile drag penalty. Special attention must be paid to disk burst, as this might lead to an

Final Technical Report CRYOPLANE System Analysis (Publishable Version)

explosion of the LH2 in the top tank. Therefore a dry bay must be created. As a consequence, this configuration is less efficient as the other solutions. It is expected that the top tank does not pose a threat to the passengers in case of fire, as the LH2 will boil off, evaporate and rise upwards.

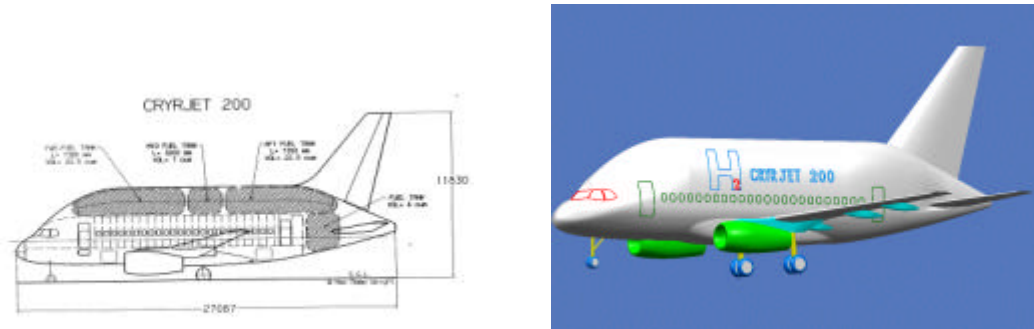

Figure 5: Regional Jet Aircraft

Short and Medium Range Aircraft

For the “Short/Medium Range Aircraft” (S/M Range A/C) tanks in an enlarged and thickened inner wing were investigated as well. It was found that the lower aerodynamic efficiency due to the oversized wing negated the benefits of the smaller top tanks. Therefore, an alternative configuration was selected with a larger tail cone volume and increased top tank cross section. The most efficient solution is to incorporate two tanks in the fuselage, one in the front and one in the rear. They balance each other and bring the least increase in construction weight and wetted area.



Figure 6: S/M Range A/C First proposal

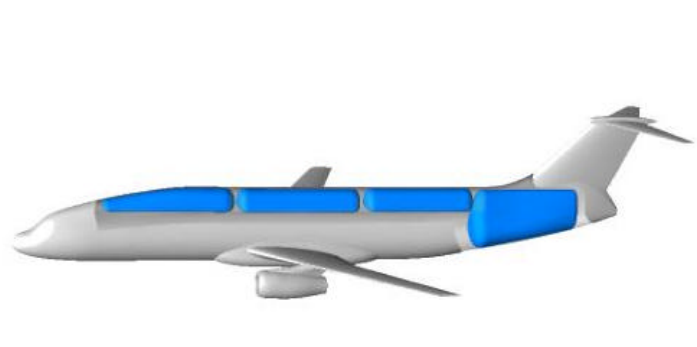

Figure 7: Revised configuration

Long Range Aircraft and Very Long Range Aircraft.

For the “Long Range Aircraft” and “Very Large Long Range Aircraft” the fuselage diameter is large enough to allow for a catwalk between cockpit and cabin alongside the forward tank. However, the structural aspects of the front tank as part of the pres-

Final Technical Report CRYOPLANE System Analysis (Publishable Version)

sure vessel have not been examined and need careful study. The same holds for the cockpit-cabin interconnection. If this interconnection can be eliminated (as discussed after the events of 11. September 2000), this layout would be feasible for aircraft of smaller size or narrower fuselage as well. The very large long-range aircraft is very similar to the one shown, except a three-deck layout in order to remain within the 80x80x80 box.

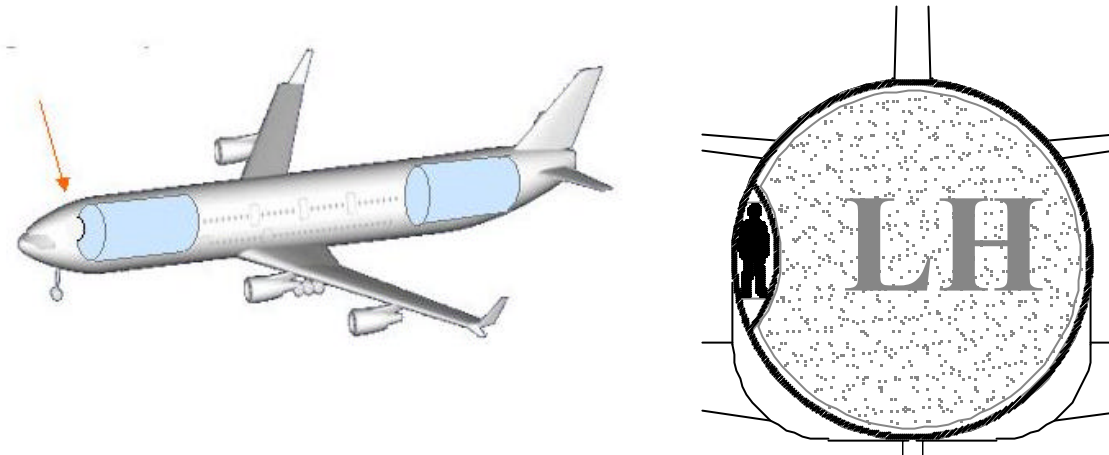

Figure 8: Location of the catwalk between cockpit and cabin alongside the forward tank.

As a check on the various solutions, an extensive parametric study was performed of the allowable combinations of fuselage cross-section, passenger capacity and design range. One example of these checks is given in the plot on the right. It appears that all designs are within the boundaries found in this study, thereby confirming their validity. In addition, other design solutions than the ones chosen were indicated as not viable, like the 5 abreast Airbus in the plot.

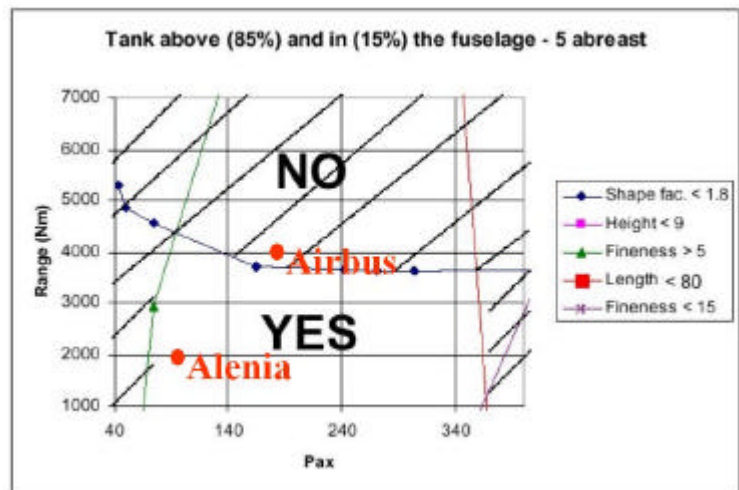

Figure 9: Parametric study - Example of a plot.

Final Technical Report CRYOPLANE System Analysis (Publishable Version)

Parametric Study

All aircraft designs have been compared to check their consistency. The tank layouts have already been discussed. The design weights show a remarkable trend of almost constant empty versus MTOW fraction of 0.68, i.e. independent of aircraft category or size (*Figure 10*).

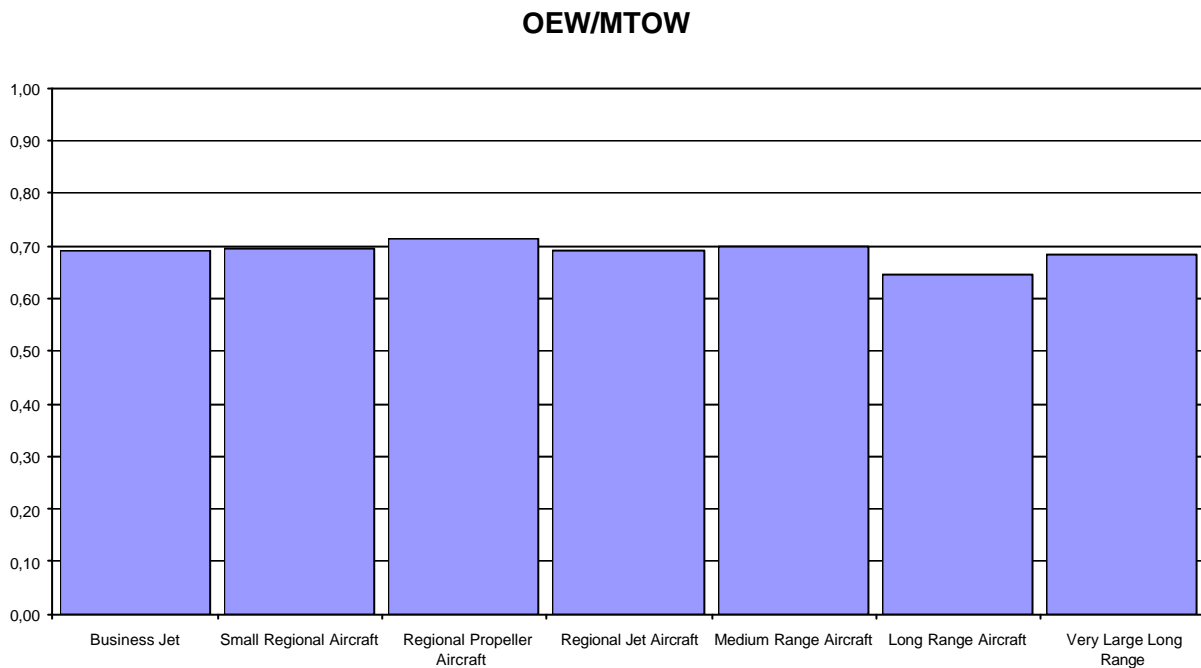

Figure 10: Fraction of operating empty weight/maximum take off weight.

On the other hand, the increase in these design weights themselves due to LH2 application does show some dependency, especially the MTOW (*Figure 11*). Irregularities may be noticed for the business jet and the VLLR category. This is to be expected since the business jet has a disproportionate fuel fraction and the VLLR is penalized by its three-deck layout. The latter is caused by the fact that this layout also affects the pressurized fuselage fuel tanks, thereby dramatically increasing their weight.

The consistency in operational cost penalty to be paid for the improvement in emissions has been investigated as well. Considering the fact that no technology leap is required for implementation of LH2, aircraft prices have been estimated on basis of empty weight only and no additional development costs have been assumed. The production price of LH2 was assumed to come down from a high factor 5 more expensive than kerosene now to equal in 2037, based on the same energy content. The energy consumption increase of LH2 aircraft is dependent on aircraft category due to the efficiency of the various tank layouts. The increase of energy consumption per pax nm ranges from 9 to 14 % if the configuration is not geometrically restricted as is the case for the business jet and the very large long-range aircraft. The 100-

Final Technical Report CRYOPLANE System Analysis (Publishable Version)

seater regional jet performs a little worse due to its very stubby fuselage as indicated in an earlier figure.

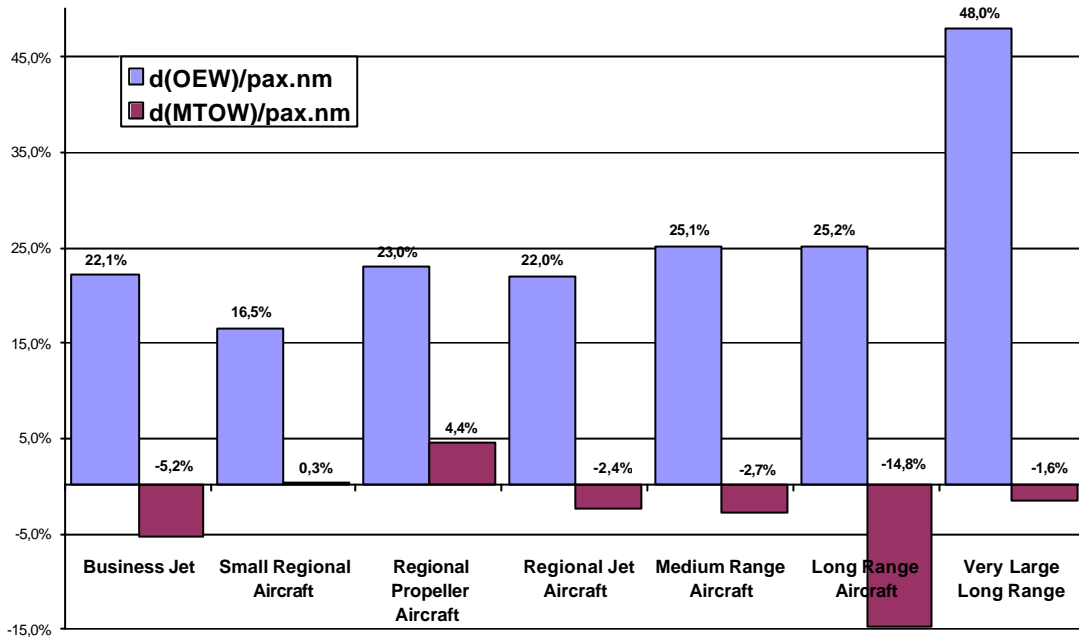

Figure 11: Dependencies between operating empty weight and max. take off weight for H2 fuelled Aircraft.

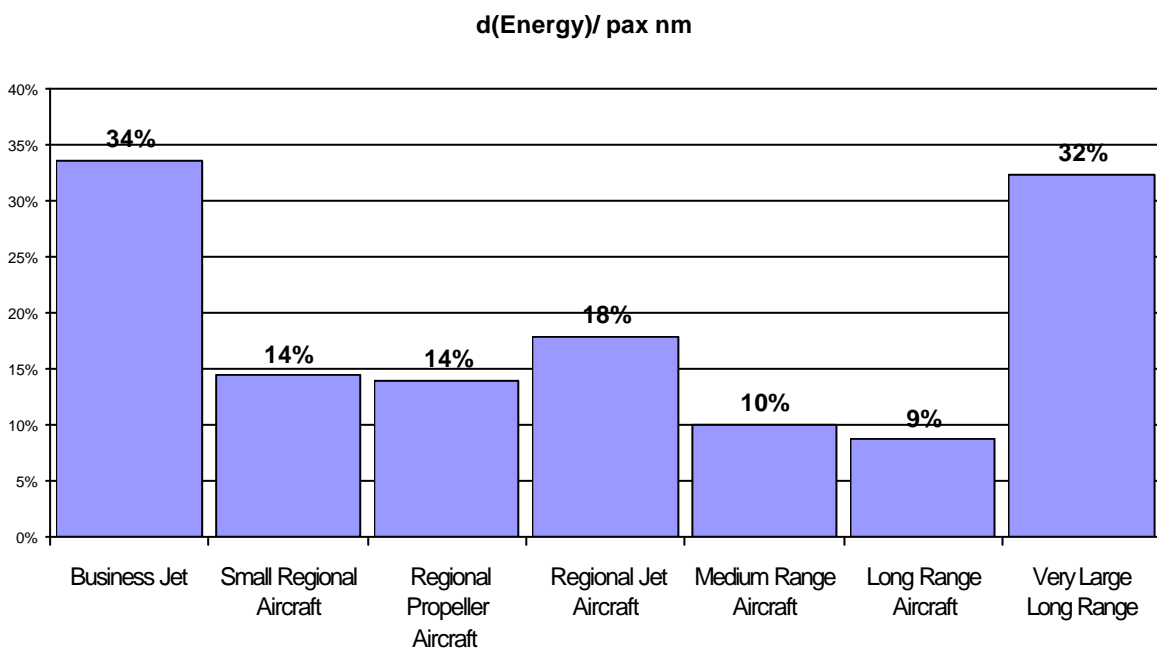

Figure 12: Change of energy consumption for H2 fuelled aircraft.

Final Technical Report CRYOPLANE System Analysis (Publishable Version)

All these considerations combined lead for a 1000 nm mission to a 25 % higher DOC now, decreasing to a break-even point in 2040. Obviously, this outcome is heavily dependent on fuel price development of both fuel types.

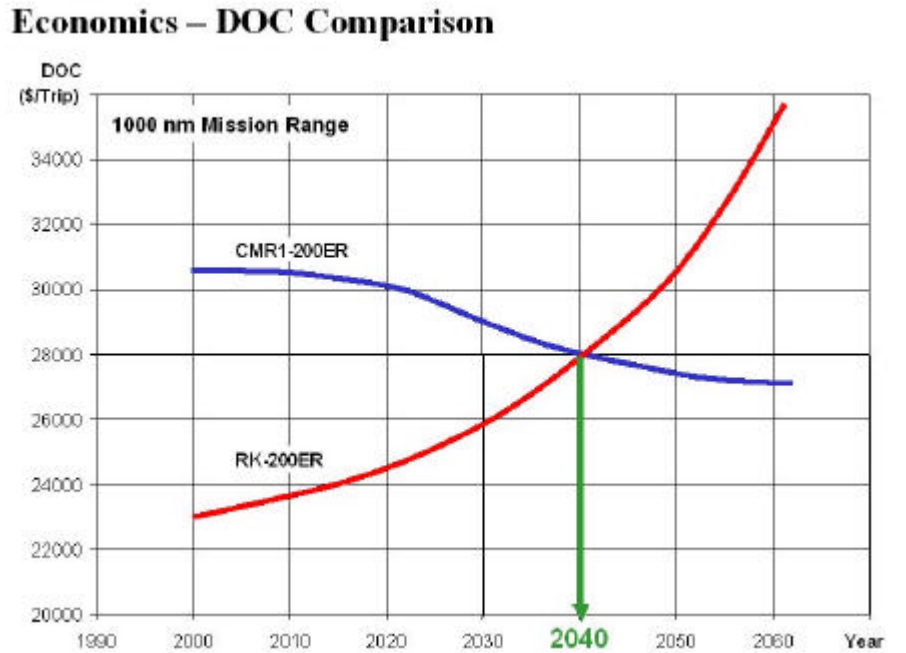

Figure 13: Calculated break even point in case of RK-200ER and CMR-200ER

Final Technical Report CRYOPLANE System Analysis (Publishable Version)

Unconventional Configurations

A score of configurations has been screened with respect to their suitability for LH2 application. It surfaced very soon that none exhibits those characteristics that met the requirement of carrying volume. Only one configuration was promising, the twin boom.

As a comparison, the blended wing body (BWB) was studied as well in the of Medium Range Aircraft category. In the end it appeared none is superior to the conventional configuration. For the twin boom configuration the large external tanks, leading to high profile and interference drag, cause this.

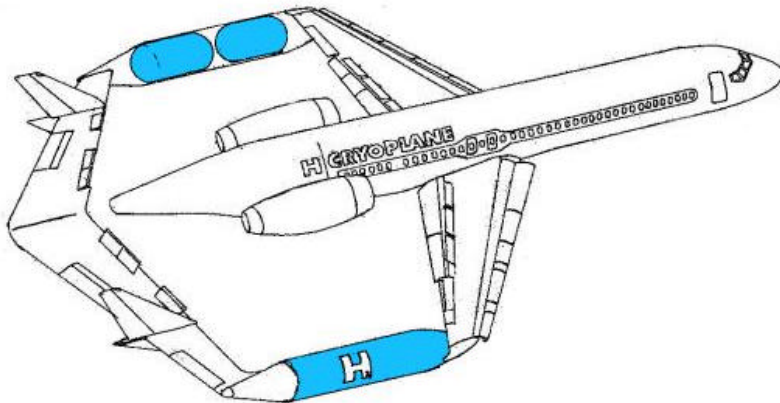

Figure 14: Twin Boom

The BWB by virtue of its profile shape is not a suitable pressure vessel. By its very shape it also has a lot of unused volume when the overall dimensions are small compared to the human being. It might be a better aircraft when applied to the Very Large Long Range category. However, first the inherent problems of the BWB should be solved, for example emergency evacuation.

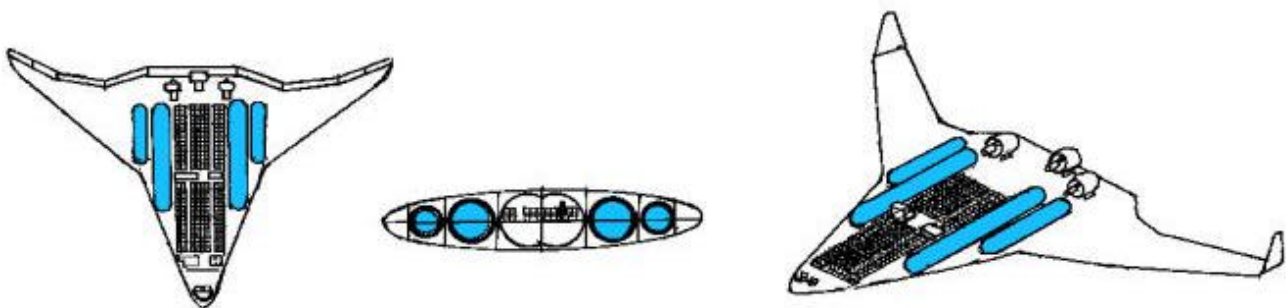

Figure 15: Blended Wing Body

Final Technical Report CRYOPLANE System Analysis (Publishable Version)

Validator

It is assumed that a “validator” aircraft is mandatory for smoothening the transition to LH2. Such a demonstrator would test the practicality of the concept and its components and provide valuable operational experience. Four steps are envisaged: a short-term “validator” to verify a LH2 system in daily use, e.g. an APU on the Airbus A300-600ST Beluga. This would entail a limited production of LH2 and limit the operational risk to Airbus and highly sensitive production transport chain.



Figure 16: Conversion of a FD 328 Jet.

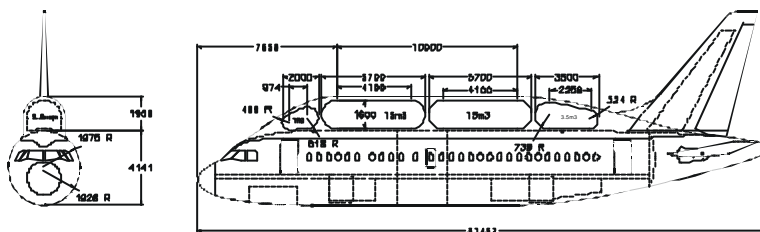

In addition, an operational APU is not a flight safety item. The second step, the mid term

Figure 17: Conversion of an existing 100-seater.

“validator”, is to demonstrate safe, reliable and environmentally compatible operation using an existing aircraft. The low cost solution could be the FD 328 (Figure 16) with under wing tanks. A solution for the mid term as well as the long term could be the Airbus A318 with tanks on top of the fuselage. The third and fourth step is to create a long-term “validator” by modifying an existing 100-seater (Figure 17) and respectively a larger one for commercial airline services. In order to minimize the impact on airlines and other customers, this would entail a limited number of connections, short-range operations and ‘easy to achieve’ LH2 infrastructure. The Scandinavian network seems most suitable for step 3, using a modified A318, and the Japanese domestic network using a modified A380.

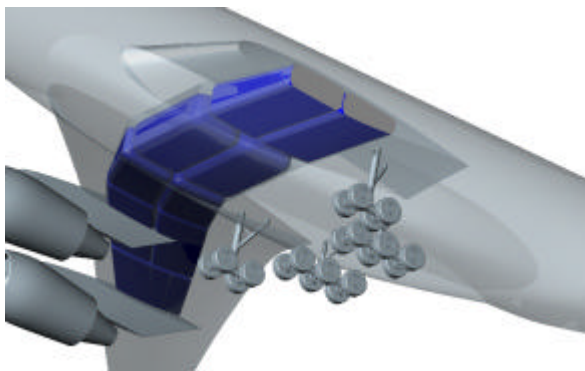

Figure 18: Modified A380 for short range operation

The Airbus A318 provides a good opportunity for introducing LH2 in two steps to minimize the risk for commercial services.

Final Technical Report

CRYOPLANE

System Analysis

(Publishable Version)

General conclusions

Various tank layouts appeared to be optimal depending on aircraft category. Crucial element is balancing of the aircraft's center of gravity. Due to the large and heavy tanks, aircraft empty weight will go up by some 25% compared to kerosene aircraft. However, due to the light LH2 maximum take-off weights will go down, especially with increasing fuel fraction. As a consequence of the bulky tanks the energy consumption increases as well, resulting in a 25 % increase in DOC as of today for a 1000 nm mission. When LH2 production cost drops to levels below that of kerosene, DOC's for LH2 and kerosene fuelled aircraft may reach a crossover point as far away as 2040. This is in line however with the motivation behind LH2 technology: a long-term alternative for kerosene when crude oil production comes to an end.

4.3 Work Package 3 Systems and Components

Overall system and components architecture

Objectives

The use of hydrogen as fuel for an aircraft has some consequences on the system side. The specific properties of hydrogen require very specific fuel system architecture, fuel system components and fuel related systems like leakage detection and fire prevention/detection and fire-extinguishing systems.

WP3 objective was to list the main systems and components to be used on the LH2 fuelled airplane and to select existing material, design and technologies for hydrogen fuelled aircraft.

During the project the most appropriate architecture had to be selected for the example aircraft of the project. Basic design features of the fuel/tank system and its components had to be defined and sized.

Discussions of the results should reveal areas for further technology research and component testing work.

Fourteen different partners have shared the tasks of WP3.

- Task 3.1 WP3-Leader – Air Liquide (L. Allidieres)
- Task 3.2 Fuel System Architecture – Airbus Deutschland (N. Rostek)
- Task 3.3 Sizing of Tanks and Fuel Supply System – SNECMA (D. Feger)
- Task 3.4 Fuel System Functional Simulation – JRC ISIS (Dr. Sarigiannis)
supported by TUHH (Prof Hapke) and ET (F. Grafwallner)
- Task 3.5 Fuel System Synergy with Other Systems – TU Delft (J. Kijnen)
supported by MTU (G. Müller)
- Task 3.6.1 Structure Materials – TU Munich (Prof. Baier)
- Task 3.6.2 Tanks (Including Insulation) – Air Liquide (L. Allidieres)
- Task 3.6.3 Pipes (Including Insulation) – Magna Steyr (Dr. Brunnhofer)

Final Technical Report

CRYOPLANE

System Analysis

(Publishable Version)

- Task 3.6.4 Valves – Air Liquide (L. Allidieres)
supported by Secondo Mona (Mr. Bulgheroni)
- Task 3.6.5 Fuel Pumps – SNECMA (Mr. Couteau)
- Task 3.6.6 Sealing – Advanced Products (G. Schieß)
- Task 3.7.1 Fuel System Control: System Principle –
Airbus Deutschland (H.G. Schulz)
- Task 3.7.2 Fuel System Control: Sensors – Sextant Sensor Unit (Mr. Barbieres)
- Task 3.8.1 Hydrogen Specific Fire Protection System: Principles and Architecture –
Airbus Deutschland (U. Auer)
- Task 3.8.2 Hydrogen Specific Fire Protection System: Sensors –
Grimm Aerosol Technik (Mr. Grimm)
- Task 3.9 Fuel System Weight Prediction – TU Munich (Prof. Baier)
- Task 3.10 System and Components for Validator Aircraft –
Airbus Deutschland (U. Wollrab)

Achievements in General

Functional requirements for refuel / defuel, fuel storage, engine and APU supply, system components, reliability, maintainability and safety were established. The fuel system architecture for the Example Aircraft was agreed. System parameters (mass flows, pressures..) were quantified and documented.

Fuel System Architecture

An overall systems architecture has been defined which is adaptable to alternative tank arrangements as suitable for different aircraft categories (see Work Package 2).

Framework specifications have been prepared for the Fuel system in general, the system specific to the selected Example Aircraft, and for the major components. The representative system will allow testing and developing critical components in a realistic environment. Certain components (e.g. heat exchanger) will need testing in special facilities.

The principle architecture selected, featuring one active tank per engine plus passive tanks feeding into these, is flexible and can be applied to other different tank arrangements.

Final Technical Report CRYOPLANE System Analysis (Publishable Version)

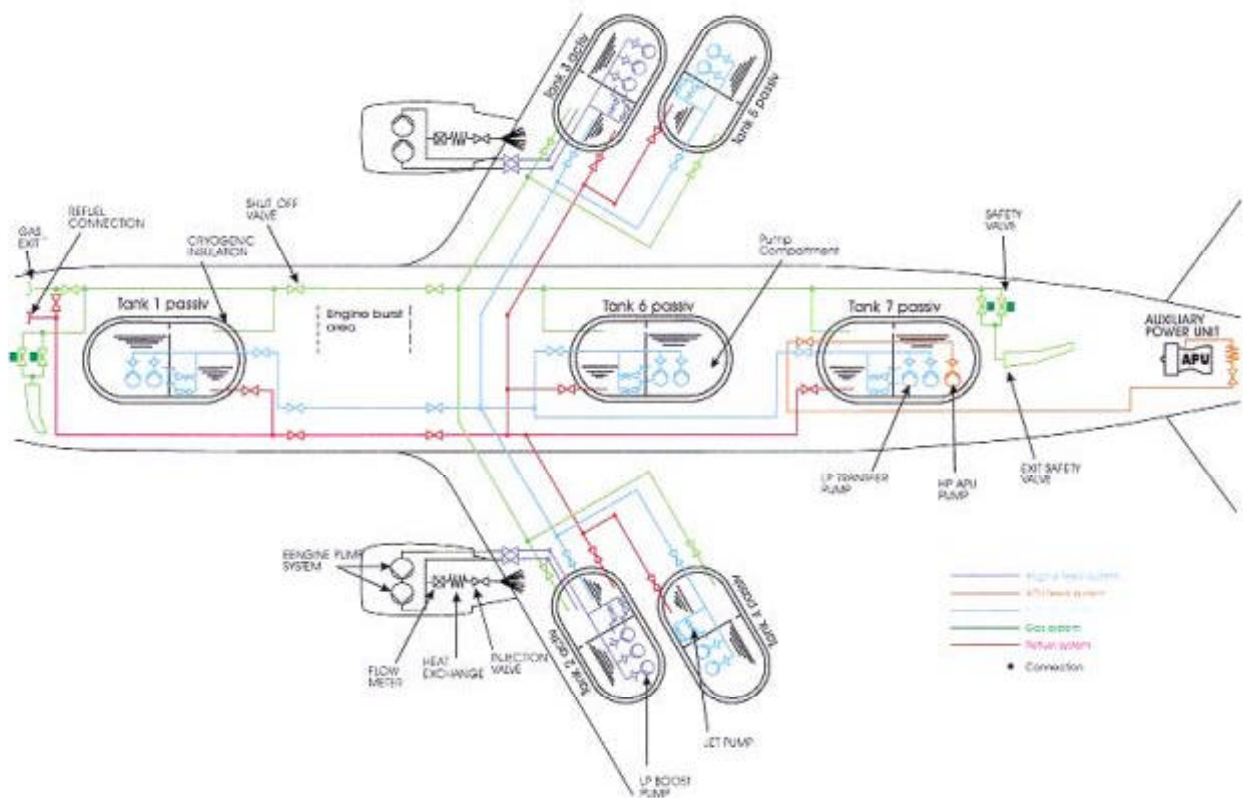

Figure 19: Fuel system architecture for the selected example aircraft.

The passive tanks serve as an additional storage tank feeding the active one. A return line from the HP (high pressure) pump outlet to the fuel tank is required in order to keep the hydrogen liquid at very low flow rates and provide F/L (Feed Line) and HP pump chill down.

The engine is fed from the respective active tank:

- this active tank is equipped with three main tank pumps inside the pump compartment,
- two pumps are working in normal operation, the third is in stand by,
- a jet pump system shall secure the filling of the pump compartment.

The main function of the system will be

- feeding liquid hydrogen up to the engine high pressure pump inlet.
- storing liquid hydrogen without out-gassing for 12 hours,

The minimum requirements of the system were

- Ground operations at ambient conditions (~ 1.2 bar, 22 K) with link to a ground out-gassing burn stack.
- No vent for taxiing, take-off and flight.
- Tank pressure to stay > 1 bar

Final Technical Report CRYOPLANE System Analysis (Publishable Version)

About 8 to 12 tons of LH2 stored in approx. 180 m³ volume must be stored in order to cope with the requirement of a medium range aircraft.

Mini Requirements Specifications

"Mini Requirements Specifications" were prepared for Piping (inc. compensators and elbows), Armatures (Valves and Outlets), Pumps and Tanks. Based on those specifications, a systematic analysis has been made on each component. The aim of such analysis have been to identify show stoppers in the development of the systems and components and to select

- The onboard fuel system shall store the required mass of fuel and provide the engines with the required quantity/ quality of LH₂.
- The APU located in the tail cone of the aircraft shall be a separate hydrogen consumer.
- The liquid hydrogen fuel is stored within independent tank group systems. For aerodynamic reason tank fairings can be applied. The outer tank structure can be likewise the aerodynamic outer tank surface.
- The tanks can be connected to each other on the liquid/ gas side to ensure all necessary sub system functions like fuel transfer/ cross feed and gas drainage.
- Refuelling and defuelling of the tank group systems shall be done simultaneously via the refuelling line using one common coupling.
- If necessary provision shall be made to purge the fuel manifold and any engine cavities
- A cockpit indication/ fuel control and metering unit system shall account for the properties of hydrogen.
- The combustor shall meet all performance requirements of the respective engine. This includes high combustion efficiency, good durability, and stable flame during engine transients, reliable ignition, acceptable combustor exit temperature profile for turbine durability, low pressure loss, and low emissions.

It is an essential requirement to achieve at least the NO_x emission levels of the conventionally kerosene fuelled engine with an additional 80 % reduction.

The projected NO_x emission levels shall be met for the 'ICAO LTO Cycle' (ref. 1) and for the 'cruise' condition.

LH2 Storage System

Two main possibilities relative to the liquid hydrogen storage are offered :

- supercritical storage at a pressure higher than 13 bar (single phase fluid) :
 - o no in-flight tank pressure variation,
 - o no tank pump.
- Liquid storage (two-phase fluid with a liquid/gas interface):
 - o easy ground operations,
 - o Tank pressure fluctuation during flight.

Final Technical Report

CRYOPLANE

System Analysis

(Publishable Version)

The supercritical storage option has been discarded due to likely heavier tank design, limited life, and more complex ground operations at high pressure. The liquid storage option is being closer to the traditional kerosene storage aboard airliners but the tank pressure will decrease or increase depending on the balance between engine consumption and tank insulation characteristics.

Synergies with other systems

The fuel cell as Auxiliary Power Unit in a commercial hydrogen driven aircraft offers a realistic potential as efficient energy source.

The high electric efficiency and the potential for reliability and low noise due to the absence of movable parts represents a clear advantage compared to a conventional gas turbine. Due to the fact that the required hydrogen is already on board a reforming system can be omitted, which leads to a more simple and cost effective system.

The more electric aircraft concept suits much better to the use of a fuel cell APU than a conventional concept as the secondary power systems like compressors and hydraulic pumps can be reduced in size and the primary fuel cell product, electric energy, is emphasized.

The modularity and efficiency of a fuel cell system offers the opportunity to power the aircraft during flight completely independent from the main engines even with respect of the ETOPS regulation.

The challenge of a fuel cell application is the rate of development of the technology to minimize the existing compromises for power density and costs.

The available power from boil off hydrogen is in most cases larger than the requested power by the aircraft systems. Therefore it might be very interesting to convert systems to use this boil off hydrogen. But it has to be taken into account during the design of the system that the availability of boil off hydrogen is not 100 %.

Further reducing the installed power losses is possible, which effects the fuel consumption directly. If the APU is replaced with a continuously operating fuel cell it might become possible to eliminate the option to use an engine for system power and allows the engine to be downscaled. Especially the requested hot bleed air can be eliminated by using an alternate anti/de-icing system and different environmental control system.

Using a hydrogen powered environmental control system has potential to replace the conventional system with hot bleed air use and an air conditioner. A more detailed analysis about the required cooling, heating and electrical power is needed to quantify the advantages.

Theoretically the surface cooling is still very interesting for the use on a cryoplane with a long cruise stage, especially if the cooling system can be combined with the anti-/de-icing system.

Final Technical Report

CRYOPLANE

System Analysis

(Publishable Version)

But before proceeding to more detailed analysis on this system, the conditions of sudden icing conditions during cruise when flying with a cryoplane fleet should be taken into account.

Reducing the boil off mass flow by using the boil-off gas for cooling the wall might be interesting but a more detailed simulation is required before more definite conclusions can be drawn.

Showstoppers

Preliminary feasibility study of a hydrogen feed system for 3 sizes of commercial aircraft have been performed. This study did not disclose any technical un-feasibilities. The principle of a mechanically driven high-pressure pump at engine level is possible. Compliance with the H₂ -temperature at injector level can be achieved by a heat exchanger of reasonable size.

However, several problems were identified:

- In idle mode, with dimensioning flux hypotheses, cavitations cannot be avoided on HP pump (tank return line).
- In all cases, heat exchanger skin temperature cannot avoid icing.
- The exchanger in the hot gas pipe seems to be important.
- Free forms LH₂ tanks feasibility has to be confirmed by detailed mechanical and thermal study with validator prototype design and construction.
-

Currently, feasibility cannot be stated, other works have to be performed:

- The reality of hypotheses at tank interface must be confirmed.
- Analysis of the behaviour in transient condition has to be done.
- Airframe and engine integration analysis have only been basic.
- Compliance with reliability and operability requirements has still to be demonstrated

Description of systems and components

Materials

Material selection is not strictly a system specific choice. However when dealing with low temperatures and hydrogen, compatibility issues must be addressed as embrittlement can occur on metallic materials in hydrogen atmosphere and cryogenic temperatures can weaken carbon steels

A literature study of all the different options with regard to metals compatible with liquid H₂ atmosphere has been done. A PC-based database system has been defined and will be developed for this particular application, in relation with the tank design.

Therefore, data for the following materials have been collected:

Metallic materials:

- Aluminium alloys

Final Technical Report CRYOPLANE System Analysis (Publishable Version)

- Steels
- Titanium alloys
- Nickel alloys and other non ferrous structural alloys

Non metallic materials:

- Carbon fibre reinforced plastics
- Glass fibre reinforced plastics
- polymeric materials (thermosets and thermoplastics)

Collected data are not completely satisfying on the following characteristics:

- hydrogen compatibility at cryogenic temperature
- hydrogen permeability for non metallic materials

Feeding pumps

The first design of a HP (High Pressure) pump has been done for the CRYOPLANE medium range aircraft. The rotation speed is 150000 rpm.

The pump design guidelines drafted by AIRBUS have been very stringent. The boost pumps located in the LH2 tanks need to have zero NPSP and still have to be designed to large vapour rate values (especially during take off).

Those low pressure pumps which goal is to provide sufficient head to the high pressure pumps mounted on the engine shaft are likely to be electrically driven pumps as they are geographically located far from any mechanical energy source. This will give a change to used submerged electrical supraconductive electrical engines as the LH2 temperature is much lower than the typical transition temperature of most supraconductive materials.

In order to have an acceptable level of redundancy, three pumps will be installed.

The high-pressure pump will be mechanically driven (gear box on engine). There will be one pump, single stage per engine, which head (exit pressure) will be approximately twice the chamber pressure level.

In order to optimise the overall system, transfer pumps from passive to active tanks have to be installed.

The main high-pressure pump is located on the engine and linked to this engine by a mechanical gear (on accessory box).

The engine is fed for the respective active tank, which is equipped with three main tank pumps inside the pump compartment, two pumps are working in normal operation, the third is in stand by.

Moreover a jet pump system shall secure the filling of the pump compartment.

Final Technical Report

CRYOPLANE

System Analysis

(Publishable Version)

The HP pump is located on the engine and linked to this engine by a mechanical gear (on accessory box). All required hydrogen for the various engine regimes is flowing through the engine-mounted heat exchanger. The fuel then passes through the flow-control valves before it is injected into the combustor. The gas drainage line to ensure the same pressure level in the active/passive tank connects the gas ullage spaces.

This preliminary feasibility study of the A/C FSS (Fuel Supply System) did not disclose any technical infeasibility:

- a mechanically-driven high pressure pump located at engine level looks feasible,
- compliance with the H₂ temperature at injector can be achieved by a heat exchanger of reasonable size.

However; in idle-mode, with dimensioning heat flux hypotheses, cavitations cannot be avoided on HP pump inlet and justify a tank return line. In all cases, heat exchanger skin temperature cannot avoid icing. The DP (Differential Pressure) induced by the HeX (Heat Exchanger) in the primary flux seems important.

Additional studies are required to complete the feasibility phase:

- Thermal conditions for the tank behaviour need to be confirmed.
- Transient analysis between operating points to be performed.
- Engine start-up and shutdown sequences to be defined.

FSS design optimisation is strongly related to the H₂ injection conditions (T_{inj} , P_{inj}).

- The cooler the LH₂, the simpler the FSS!
- Feasibility of a sub-cooled injector ($T_{inj} \gg 30\text{-}35\text{ K}$) to be checked.

Next step is to validate related technologies at component level:

- BP/HP pumps,
- sub-cooled LH₂ injector test.

Tanks

The fuel system will be more complex than for a conventional kerosene aircraft, as the liquid hydrogen virtually is a boiling liquid, which can evaporate. Air Liquide has developed an expertise on cryogenic tank with the Ariane 4 and 5 programs, however components cannot be taken directly from space technology, as aviation requires much longer component lifetime.

Insulation must be light and effective (an aircraft must be able to park without losing too much LH₂), but also reliable; it must not breakdown due to some small damage.

Insulation of the CRYOPLANE tanks will be chosen from the following insulation technologies: foams (22 standard different types available), or super insulation type (customized fabrication)

Final Technical Report

CRYOPLANE

System Analysis

(Publishable Version)

For weight/cost/boil-off reasons super insulation seems to be necessary for a dedicated APU LH2 tank.

Due to their non cylindrical shape, tank structure will not be light, and LH2 storage capacity will not be optimised, privileging aerodynamic shape rather than optimised tank volume / weight (sphere) ratio.

High purge temperatures will disqualify some of the polymeric insulations, which are available on the market.

As well as structural materials, insulation material is an important point. Insulation characteristics were collected in order to select the most promising material for the LH2 storage of the CRYOPLANE :

- Foam: 55 different types
- Multi layer insulation: 15 types
- Other non classical (powders, etc...)

The selected mode of operation (12 hour autonomy requirement) has pointed to the use of multiplayer insulation.

If vacuum breaks, only 200 seconds are enough to reach the relieving pressure. In case the vacuum breaks and the system is submitted to fire, less than 20 seconds are necessary to reach the relieving pressure. These figures being very rough orders of magnitude.

Non-cylindrical tanks seem not to be adapted for pressure and particularly vacuum. This leads to a difficult integration in the plane, for which the layout must be reviewed.

On a mechanical point of view; two different shapes were calculated and a compromise between maximum volume and lighter weight was not easy to find.

The main problem to solve is to find or create convenient space in the plane to place large tanks, medium or smaller ones while keeping a simple tank geometry.

The two different shapes calculated show that the compromise between maximum volume and lighter weight is not easy to find.

On storage issues, the system analysis has concluded that further investigations are required on subjects such as:

- Pressure build up in case of vacuum loss
- Vibration resistance of the multi layer insulation
- Feasibility of flat shape LH2 tanks with vacuum multi layer insulations
- Pressure control system
- Pressure fluctuation prediction model
- Coupling of pressure resistance calculation and aerodynamic loads on the tank structure

Final Technical Report

CRYOPLANE

System Analysis

(Publishable Version)

Pipes

Analysis of pipes recommends that for ground operations such as liquid or slush hydrogen transfer from tank to vehicle vacuum-jacketed lines with radiation shielding are suitable. Cryogenic composite pipes should replace operations feed pipes. The main objective was to demonstrate the feasibility of composite piping for both design concepts, the single-walled cryogenic composite pipes and the double-walled composite pipes and to define feasible manufacturing technologies. Further development to full composite pipes with composite tube and composite flange connections is recommended. In order to avoid any gluing technique at cryogenic temperatures a special filament winding technology for such components may be developed. Advantages: weight saving and heat leak reduction.

Lines on the CRYOPLANE to the engine need to be Cryogenic Composite Lines with low radial and axial thermal flux. Their advantages are

- Low mass
- Rapid chill down
- High strength
- Resistance to handling damage
- Inherent vibration damping

However the feasibility of such lines of systems, which require high integration levels (non straight lines are required) is not obvious.

Valves

Conventional valves for space application have short lifetimes, and high vibration resistance. Conventional cryogenic valves for liquid hydrogen are heavy; therefore both types are not adapted for the CRYOPLANE.

In terms of seal performance and life, it is preferable to separate the shut-off and regulating functions although this adds numerical complexity. Control strategies seem to prefer an electric regulation with a hydraulic shut-off actuation although pure hydraulic or pure electric actuation systems could be foreseen.

If a separated function valve system were chosen, ideally the simpler solution would be for a electromechanically regulated ball valve with a poppet shut-off valve powered automatically through an accumulator fed by engine oil. A hydraulically powered regulator is possible. However, it is considered to be more complicated than the equivalent electrical system.

If a combined system were chosen, then it would be preferable to have an electric actuator as long as enough back-up power can be guaranteed to assure valve closure in the event of system electrical failure. However, problems concerning loss of electrical control have not yet been looked at although they are not considered insurmountable at this stage.

Final Technical Report CRYOPLANE System Analysis (Publishable Version)

Given the control precisions demonstrated by both types of actuators, it is possible to control hydrogen flow to within 0.11% of total mass flow, which is (roughly estimated) to about 0.5 g/s.

In terms of valve weight, each valve would have a space envelope of about 50mm cube and weight of 1kg each. Given the size of the valves, we can extrapolate the actuator sizes. They would each weigh not more than 2kg to 3kg depending on their complexity.

Therefore, a combined system would be about 4.5kg (not including redundant hardware) and a separate system about 6 kg.

Sensors

There is currently no sensor available on the market, which is compatible, both with the specific requirements of the aeronautic industry and the physical properties of liquid hydrogen. Therefore specific components have to be developed.

- Sensors measuring the fuel level at various points within each tank.
- Sensors measuring the temperature of the contents of the system (tanks, pipes), which may be liquid or gaseous hydrogen
- Sensor measuring the pressure of the contents of the system (tanks, pipes), which may be liquid or gaseous hydrogen
- Sensors providing the flow rate of fuel to the individual engines, from idle to Max TO (Take-Off) power
- Available designs compatible with LH2 environment

Ultrasonic flow sensors seem to be the most adapted solution for the flow rate measurement. These sensors:

- have a sufficient accuracy with contra-propagation sensors technology
- are not in contact with liquid hydrogen with use of wave guides
- are compliant with the maintainability requirements

Coriolis sensors can provide another solution in next years if appropriate technologies for MEMS (Microelectromechanical System) devices are developed.

Several types of sensors can satisfy the level measurement functionalities.

For the continuous level measurement:

- Differential pressure method,
- Capacitance probes,
- Radar or micro-wave sensors,
- Ultrasonic sensors.

For the detection of particular levels:

- Capacitance probes,
- Micro-wave sensors,
- Ultrasonic sensors,
- Optical sensors.

Final Technical Report

CRYOPLANE

System Analysis

(Publishable Version)

There are several possible choices for the pressure sensor principle. The choice of the right principle will be according to the main following criteria:

- Range and sensibility: advantage for vibrating type,
- Measure accuracy: advantage for vibrating and capacitive types,
- Robustness and simplicity of the transducer: advantage for strain-gage,
- Simplicity of the electronics to treat the measure: advantage for strain-gage.

In all cases, a three way manifold must be provided so that the replacement of a sensor can be made without the emptying of the tanks and pipes.

The replacement of a sensor requires also the loading of the new calibration parameters within the pressure computer.

Modern MEMS technologies shall be preferred for the transducer. An adequate packaging must be provided for the insulation of the detector diaphragm. A metallic diaphragm may be necessary for insulation; this may result in a decrease of the accuracy of the sensor. However, convenient technologies, at transducer level, compatible with GH2 may be considered if the insulator diaphragm is not preferred.

Any sensor, which has been taken into consideration in the “CRYOPLANE system analysis” had to meet the requirements to prevent ignition hazards caused by the possible presence of hydrogen after a leak.

To avoid the migration of the hazardous area to the airplane cabin, particular care should be given to the physical separation between H2 exposed areas and cabin (absence of cracks in the structure, etc...)

Active protections devices such as ventilators to keep lower concentration in confined areas lower than 0.4% H2 in air as well as passive UV detectors are applicable. Physical protection shield resisting to high temperature based on Carbon or Kevlar must be used.

Sealing

Seals and sealing systems are used in cryogenic services for many years. The use of such seals has been mainly restricted to the space technology, medical industry and superconductivity.

In the last decade some further applications for cryo-technology have been developed for example the utilisation of liquid hydrogen as an environmentally friendly carrier for transportation and energy supply systems.

In an hydrogen fuelled aircraft, a sealing system must maintain a long lifetime compared to the very short lifetime in a launch rocket. Safety standards must be considered in order to avoid uncontrolled escape of hydrogen, which could cause ignitable gas mixtures.

Final Technical Report CRYOPLANE System Analysis (Publishable Version)

Based on the experience in space applications a number of sealing materials and designs have been successfully approved. Polymers are very suitable for dynamic sealing systems due to their excellent mechanical properties at low temperatures. Austenitic Stainless steels and Nickel Based alloys are incorporated in cryotechnology with great success.

However the long- term behaviour of these materials at low temperatures must be investigated further.

Hydrogen embrittlement may be not a reason of concern in short term launch missions, however it is of great concern for an hydrogen fuelled aircraft.

Cryo - tribological tests have been performed at the federal institute for materials Research and testing in the last years. These test dealt with various polymer materials running against uncoated and coated surfaces.

Cryogenic tests with complete sealing systems however have rarely been performed and almost no literature is available.

Since real testing under cryogenic conditions is very time consuming and expensive it would be necessary to use finite element analysis as a powerful tool to determine the optimal sealing system.

A comprehensive computer model for sealing systems in liquid hydrogen considering the long-term behaviour of such system is not available today.

Apart from the finite element analysis it is necessary to continue with further material testing in order to determine the best possible material selection under the given circumstances.

The results of such testing and computer modelling would be of great interest for a number of industrial applications where long term behaviour of sealing materials and systems is requested.

Weight prediction

One of the goals of the overall system and component study is to compile all available information on components in order to make a weight prediction module. However, the data base at this stage is too small to allow any kind of reliable weight estimation, but established procedure has growth potential by allowing further inclusion of data when available.

Conclusions

This system analysis on components has demonstrated sufficiently that technology and design principles for H₂ fuel tank and H₂ fuel systems are available today. A layout of a fuel system, including all subsystems like H₂ and fire detection, has been performed and evaluated. No showstopper for the further development of the CRYOPLANE has been found. However technical work has to be done in order to adapt

Final Technical Report CRYOPLANE System Analysis (Publishable Version)

and optimise the existing materials, components and modules to the needs of an aircraft design.

More detailed analysis has to be performed in a first approach by finite element calculations and modelisation in order to prequalify selected options and components.

In a second stage, validation of the different concepts studied in the system analysis must be qualified on a validator aircraft (scale <1) or by building up a representative complex system in a ground laboratory installation, testing its behaviour under normal and failure conditions.

Results will be used to calibrate computer models, which in turn will allow analysing many more operational situations and optimising the system.

4. 4 Work Package 4 Propulsion

Introduction

In WP4 there are 8 Tasks and the work of each Task is summarised below.

Task 4.1 Work Package Integration and Leadership (Cranfield University SME, UK)

Task 4.2 (Minimum Change Engine Configuratons) at U.P. Madrid, Task 4.3 (Unconventional Engines) at Cranfield University, UK, Task 4.4 (Combustion) and Task 4.7 (APU) – both at FH Aachen, Task 4.5 (Cryogenic components) at SNECMA, Task 4.6 (Engine Controller) at Diehl Avionik Systeme GmbH in Überlingen/Germany, Task 4.8 (Validator aircraft propulsion) at Airbus Deutschland in Hamburg/Germany.

Task 4.2 Minimum Change Engine Configurations (Universidad Politecnica de Madrid)

The purpose of this Task was to „determine the feasibility of hydrogen fuel for existing gas turbine engines with minimum component changes, and quantify main performance characteristics“ (GRD1-1999-10014).

Work standard

The first part of the work consisted of establishing technical standards, which would allow comparison of results between Task 4.3 - unconventional engines (at Cranfield) - and Task 4.2 – conventional engines (at Madrid). The objective was to identify the effects on engine performance and design of changes from kerosene to hydrogen fuel in a conventional engine.

The technical standards work consisted of agreement of three items in the propulsion group, especially between Task 4.2 and Task 4.3. These were agreed at an early stage of the project.

Final Technical Report

CRYOPLANE

System Analysis

(Publishable Version)

Item 1: Engine thermodynamics, performance assumptions, standard atmosphere, gas properties, fuel properties were all agreed. Fuels have been characterised by their Lower Heating Value and chemical formula.

Item 2: Selection of computer code(s) to be used; the commercial code GasTurb is available at the Universidad Politecnica de Madrid (UPM) and it has been used in Madrid for simulation. To calibrate the code, a representative engine for Cranfield-Madrid cross-calibration of software was agreed (a typical V2500). This allowed Cranfield-Madrid code cross-calibration when using kerosene.

Item 3: Computer code modifications were identified to permit engine simulation when using hydrogen as a fuel. As it was at the start of the Project, GasTurb allowed conventional engine simulation. However, it needed important additions to simulate possible „conventional“ engine configurations when using hydrogen as fuel; this is a common problem for any computer code devoted to aircraft engine simulation. Basic modifications included fuel and gas property changes including the effect of fuel temperature change, burner calculation methodology and implementation of a heat exchanger at different engine aerodynamic sections whilst keeping in mind the need to minimise engine hardware changes. The heat exchanger is required to heat up and vapourise the hydrogen fuel, as well as getting possible benefits on specific fuel consumption (SFC). After modification, the code required further calibration and this was achieved satisfactorily.

Work Summary

The work, carried out within this project, can be summarised as follows:

Methodology. The GasTurb code methodology has been changed to allow hydrogen-fuelled engine simulation, as described above.

Simulated Engines. Four engines were selected – three turbofans (BRM710-48, V2527A5 and Trent884) and one turboprop (PW120) - trying to cover different aircraft sizes and ranges according WP3 Aircraft Configuration requirements. The simulations included different configurations – heat exchanger at different aerodynamic engine sections - as well as the influence of fuel temperatures. Design points were fixed at Sea Level Static (SLS); these were computed by closely matching public data - basically cycle, net thrust and Specific Fuel Consumption (SFC). Off-design simulations were then done and the results compared with cruise data in the public domain. The results at cruise conditions for aircraft-engine combinations were good: they matched well the available data in the public domain.

Data supplied to Project. All engine data, according to project needs, were provided to the other Tasks: in particular, performance, weight, emission parameters and dimensions. In-depth studies were carried out for the two cases of a fuel heat exchanger placed at exit of the low-pressure turbine and in the external aerodynamic

Final Technical Report

CRYOPLANE

System Analysis

(Publishable Version)

stream. Two different fuel temperatures were studied; these two temperatures were fixed to cover fuel control system requirements. Data of estimated engines, based on current conventional engines but improved to the technology standard expected in year 2010, were also provided.

Hardware changes. The possible dimensional changes on turbines, beside simple dimensional nozzle changes, have been considered; the dimensional changes required are minimal and are easily feasible in the case of conventional engines.

Conclusions for Task 4.2 (Conventional Configurations)

From the studies carried out (aside from benefits from a point of view of emissions, not included in this task) it can be concluded, that:

- The project of a conventional turbo engine, burning hydrogen, seems to be feasible with minimum hardware changes.
- The SFC (Specific Fuel Consumption), with hydrogen, is about one third (1/3) of the SFC using kerosene. This means, with hydrogen, a large fuel mass saving, offset by the increase of fuel volume. Hydrogen shows a small benefit in energy SFC (SEC)(Specific Energy Consumption) over kerosene of order up to 3%, the amount depending on the fuel temperature and the accounting of the heat to raise fuel temperature.
- The engine runs cooler, when using hydrogen, for the same thrust level. This lower temperature will increase engine life. It will run at a TET (Turbine Entering Temperature) of about 30-50 K lower, depending on engine size and configuration.
- Models of the performance and other characteristics of 4 conventional engines fuelled with hydrogen are now available to the scientific community.

Task 4.3 Unconventional Engine Configurations

(Cranfield University, School of Mechanical Engineering (SME), UK)

Task 4.3 covers studies of possible new unconventional gas turbine engines for aircraft, using hydrogen as fuel.

Unconventional gas turbines can show improved performance by using, in various ways, the very cold heat sink provided by the hydrogen fuel. The hydrogen is stored in the aircraft tanks as liquid at about 20K, just above atmospheric pressure. Before injection into the engine the hydrogen must be processed to a gas at over 150K and must have sufficient pressure to drive the fuel injectors – about twice the engine combustor pressure. The required fuel temperature increases can be achieved using heat supplied from the engine that would otherwise be wasted, thus giving an overall performance advantage over conventional gas turbines. Various ancillary cycles can also be devised to improve performance.

Final Technical Report CRYOPLANE System Analysis (Publishable Version)

For the studies reported herein, a V2527A5 turbofan engine has been taken as the datum.

Initial Studies

It was found, from a comprehensive literature study, that there are many published unconventional configurations but most were more suitable for ground-based use. Additionally, some unpublished configurations were invented and investigated. All potentially useful ideas were then studied in a preliminary way. This revealed that there were four configurations worth deeper study for aircraft use, and these are described briefly below.

Performance Calculation Methods and Code

The most important calculations required for potential new engine configurations are performance figures at various operating points in the flight envelope. From these calculations, engine components can be configured and sized, leading to initial estimates of engine size and weight.

These performance calculations require a computer code with “off-design” capability, able to simulate both kerosene and hydrogen fuels. For the studies of unconventional engines, the code must also be capable of being adapted to cover the various configurations of interest. The code finally chosen for this work was the “Turbomatch” code of Cranfield University. It met all requirements except the simulation of hydrogen fuel. Task 4.2 accordingly modified it to simulate hydrogen fuel using the same method employed on the conventional engine studies. This was then satisfactorily calibrated against two other codes, using conventional engine configurations, hydrogen fuelled. One of the calibrating codes was GasTurb, which was used by Task 4.2 to study hydrogen fuelled conventional gas turbines.

Best Unconventional Engine Configurations

The four best hydrogen fuelled unconventional engines studied (called Engines A, B, C, and D). All use the conventional V2527A5 engine as their basis. The results are summarised below and in the Table.

Basic V2527A5 Engine (Datum): this kerosene-fuelled turbofan engine has two shafts and separate jet exhausts. It has a booster compressor on the same shaft as the fan.

Engine A uses the hydrogen fuel to cool the core compressor air.

Engine B, although judged impractical, has a small topping cycle (cooler, compressor, combustor and turbine) operating on air tapped from the engine compressor and providing fuel-rich mixture to the main engine combustor.

Engine C uses the hydrogen to cool the turbine cooling air, allowing higher operating temperatures. By fitting a larger fan, the bypass ratio is increased.

Engine D takes waste heat from the engine exhaust into the fuel so that this heat is restored to the engine cycle.

Final Technical Report CRYOPLANE System Analysis (Publishable Version)

Durable and effective heat exchangers (apart from the need for new combustors to burn hydrogen) are the prime hardware requirement. However, this study has established that the size of these heat exchangers is relatively small and in themselves they would not significantly influence the overall size of the engine installation.

For engines A, C and D, detailed performance calculations have been made, and are summarised in the Table below. Component modifications have been assessed, and hence an estimation of the changes in engine weight and size made relative to the datum V2527A5. In particular, when the by-pass ratio or the compressor pressure ratio is increased, the increase in fan diameter and the number of compressor stages are considered. Where the LP (Low Pressure) turbine loading is changed, the number of additional turbine stages is calculated and the total engine length and weight are re-estimated.

Consideration has also been given to the practical feasibility of the modifications suggested, and where these involved fundamental changes to the engine's structure, a solution in principle has been looked for. In particular, for Engines A, C and D, the size (surface) of the extra heat exchangers has been calculated with approximation methods, and it has been verified that it can be fitted, when required, in the appropriate position.

All the engines may be scaled within reason. Furthermore, the concepts of Engines A, C and D may be applied to larger and smaller engines such as the Trent 884 and BR710.

Engine Weight Calculation and Definitions

Engine weights have been estimated approximately and are quoted in the Table. Weights include turbo-machinery, combustor, accessory gearbox, oil pumps, hydraulic pumps, electrical generator, air cooler, engine mounted fuel and hydraulic lines. Weights exclude intake, cowling, thrust reverses, final nozzle(s), electronic control system, fuel control hardware not mounted on engine.

Performance Data Definitions

In the Table below, the performance figures are defined as follows.

Fuel Calorific values: Hydrogen 120 MJ/kg. Kerosene 43.6 MJ/kg

Performance calculations include: turbo-machinery efficiency, combustor pressure losses, intake loss, bypass loss, accounting for heat supplied to hydrogen fuel. Performance calculations exclude: hot jet-pipe loss, combustor inefficiency. There are no off-takes of power or air for any purpose external to the engine.

Conclusions for Task 4.3 (Unconventional Configurations)

An exhaustive search for potential new unconventional hydrogen fuelled engine configurations was carried out by literature study and also by invention using fundamental principles. A short list of the best 4 engines (A, B, C, D) was investigated for

**Final Technical Report
CRYOPLANE
System Analysis
(Publishable Version)**

competitiveness in performance and weight. Practical aspects were also investigated. Engine B was found impractical.

Comprehensive performance, weight and size information for the recommended three engines, A, C and D, has been published for the use of the CRYOPLANE project.

All three engines offer useful advantages in fuel consumption relative to the conventional datum engine fuelled with hydrogen. Engines A and C also offer improved thrust to weight ratio at take-off. This is summarised in the Table (*Figure 20*) below.

**Final Technical Report
CRYOPLANE
System Analysis
(Publishable Version)**

Comparison of Engines

	Units	Base Engine V2525A5 Kerosene	Base En- gine V2525A5 Hydrogen	Engine Unconv. A	Engine Unconv. C	Engine Unconv. D
				Core air Cooled	Cooled Turbine Cooling Air	Exhaust Heat Re- covery
Diameter	mm	1613	1613	1668	1834	1613
Length	mm	3200	3200	3295	3394	3200
Weight	Kg	2370	2370	2499	2800	2370
Performance at Take Off (SLS, ISA+10):						
Bypass ratio		4.8	4.8	5.2	6.5	4.8
Overall Pres- sure Ratio		28.5	28.5	36.63	28.5	28.5
TET	K	1470	1472	1472	1613	1472
Inlet Airflow Rate	Kg/s	355.6	355.6	380.1	459.8	355.6
Thrust	KN	117.9	121.4	129.5	155.5	120.4
T/O Thrust/Weight ratio	N/kg	49.8 Datum	51.2 +2.8%	51.6 +3.6%	54.6 +9.6%	50.8 +2.0%
Performance at Cruise (11 km, 0.8M, ISA):						
Thrust	KN	22.56	23.25	24.77	29.72	23.04
TET	K	1248.5	1256.4	1268.6	1378	1251.9
Sfc	Kg/(s*M N)	15.994	5.755	5.502	5.6694	5.632
ESFC = Sfc x Cal Val	J/s / MN	697.3 DATUM	690.6 -1.0%	660.2 -5.3%	680.3 -2.4%	675.8 -3.1%

Figure 20: Comparison of engine data.

Note: Enthalpy to process hydrogen included in accounting.

Final Technical Report CRYOPLANE System Analysis (Publishable Version)

Task 4.4 and 4.7 Combustion Chamber and Emissions (Engine and APU) (Fachhochschule Aachen, Germany)

These two Tasks are reported together because they both involved the emissions of combustors. Task 4.4 covers the engine and Task 4.7 the Auxiliary Power Unit (APU).

The main subjects of these tasks were to estimate and/or measure the NO_x emissions of modern combustion chambers for both kerosene and hydrogen fuels. The proposed hydrogen combustion technology was based on engine test experiments on the Honeywell APU GTCP 36-300 engine, which were done at the Fachhochschule Aachen. The engine control system was supplied by DIEHL.

Kerosene Fuel

In the Task reports, current and expected kerosene engine cycles are described. Comparisons are made between main engines and APU's. The NO_x emissions of conventional kerosene engines for sea level conditions are given together with the ICAO-limits, and a possibility for the calculation of cruise values based on well-known engine data is specified.

From the considered unconventional kerosene combustor concepts, the **Lean Pre-mix Prevaporize** (LPP) kerosene combustor - though probably offering the largest NO_x-reduction potential - is still in an early state of technological development. Due to the danger of flame flash back or premature burning, LPP introduces considerable risks into aircraft engine operation, as has been experienced in preliminary rig tests. Simultaneous achievement of low CO and UHC levels is difficult. Therefore, the LPP concept should not be considered as a short-term candidate for unconventional low NO_x combustor design.

Catalytic combustion, if at all feasible, is a long-term future candidate for aircraft engine application and has been excluded from the present considerations.

Both the **staged combustor** and the **Rich burn-Quick quench-Lean burn (RQL)** combustor represent more promising concepts for application in kerosene combustion, both concepts having similar NO_x-reduction potentials of up to 60 percent of present aircraft NO_x-emissions, if simultaneously the CO- and UHC-emissions are taken into account. The RQL concept seems to be of easier design and poses less complex challenges for control and operation, since fuel injection is not divided into two stages as in the case of the staged combustor. The latter, on the other hand, may be more flexible to meet part load / idle operation conditions.

The purpose of the European Low-NO_x Programmes is to demonstrate a reduction of the NO_x emissions to CAEP2 minus 60%, compared with the 1996 ICAO regulation

Final Technical Report CRYOPLANE System Analysis (Publishable Version)

for large engines. It may be stated that that this target may be met by the RQL-concept as well as by staged combustion configurations.

Hydrogen Fuel

The different research programs dealing with hydrogen as fuel for jet engines are described in the Task reports. The only pollutants emitted by hydrogen gas turbine engines are the oxides of nitrogen ($\text{NO}_x = \text{NO} + \text{NO}_2$) due to the gas phase reaction condition (presence of molecular nitrogen and atomic oxygen plus high temperature levels in the combustion zone). Normally NO is formed in much larger amounts than NO_2 , and the latter is thought to be formed by further reactions of NO. Hence, NO-formation determines the total amount of NO_x emitted.

Following the theory of Heywood and Mikus (ref. 2), a key parameter for NO-reduction is the 'mixedness' of a combustion system. Under lean fuel gas turbine combustion conditions, the lowest level of NO-formation would be found for homogeneous or premixed combustion. Many present natural gas fired utility gas turbines make very successful use of fuel premixing.

However, when fuels with high reactivity such as hydrogen are premixed with a turbulent air flow and under the gas turbine conditions of high compressor exit temperature and pressure, mixtures of high flame velocity are formed, which introduces the risk of flame flash back and damage to the combustion system. This has already been experienced during several premixed combustor tests.

The danger of flash back can entirely be excluded by choosing the diffusive mode of hydrogen combustion, where hydrogen is immediately injected into the combustion zone, and mixing and combustion take place simultaneously. The key question under these circumstances is, how the mixedness of a diffusive combustion system may be enhanced in order to minimize NO-formation.

To meet such a requirement, the "micromix" diffusive hydrogen combustion principle was developed at FH-Aachen, which applies two basic provisions:

1. The geometric extensions of the combustion zones are minimized providing a very large number (typically >1000) of very small diffusion flames ("flamelets") uniformly distributed across the burner's main cross section. Hydrogen fuel, thanks to its high reactivity, allows a very high degree of miniaturization. Admissions must be made to the costs of manufacture and to the fact that flame stability at engine idle condition decreases with reduced flame dimensions.
2. The available pressure loss of a gas turbine combustion system is - as far as possible - used to provide energy for the dissipative turbulent mixing process between hydrogen and air, thus minimizing the length of the local stoichiometric flame regions, where the gas phase NO-formation reactions are most intense.

Following these design guidelines, three "generations" of „micromix“ hydrogen combustors were developed and tested (a) on an atmospheric test rig and (b) integrated

Final Technical Report CRYOPLANE System Analysis (Publishable Version)

into the Airbus A320 APU GTCP 36-300. To do this, the APU fuel system, the hydraulic system, the controller and the control software have to be changed. This was done in close cooperation with DIEHL Avionik Systeme (see TASK 4.6)

For the most advanced Micromix combustor of the third generation, a 77.6% NO_x-reduction was measured during tests of the APU GTCP 36-300 at full shaft power of the load compressor and zero generator power, compared with kerosene operation of the base line, unconverted production engine. Using this result, a theoretical assessment was made of engine NO_x-emission reductions by application of the "micromix" hydrogen combustion principle to eight different typical aircraft main engines. For the selected set of gas turbines, an average NO_x-emission reduction of about 75 percent (related to kerosene operation and SLS take-off condition) was calculated.

Noise measurements showed that the noise level of the combustor is within the level of the kerosene engine, so that no change is seen.

A short exercise on hydrogen embrittlement finished the work in these two Tasks: the result is that hydrogen will influence the stress factor of the material used for jet engines but this effect is small. Nevertheless it has to be taken into account for the design of a new engine.

Task 4.5 Cryogenic Components of Fuel System („Equipped Engine“) (SNECMA, Vernon, France)

The task 4.5, which SNECMA was responsible for, was dedicated to cryogenic components of equipped engine. These components include:

- the high pressure pump which provides injection pressure
- the fuel control valve to be articulated by the engine controller
- the heat exchanger to raise fuel temperature to a level ensuring stable combustion at low NO_x.

Main conclusions concerning feasibility studies are given hereafter for the fuel control valve and the high pressure pump.

High Pressure Pump

Considering the rather low mass flow and the high-pressure rise needed, the high-pressure pump is made of a centrifugal stage (impeller).

An inducer which role is to avoid cavitation in the impeller precedes this impeller.

Take-Off conditions have been used as design requirement. Tip speed has been limited to nearly 450 m/s to ensure a high safe life. Taking into account the environment, such as inlet and outlet pipes diameters, this led to a 60 mm impeller diameter and a 150 000 rpm rotation speed (T.O. conditions).

**Final Technical Report
CRYOPLANE
System Analysis
(Publishable Version)**

The aim of this study was not to design comprehensively the High Pressure Pump, but to show the feasibility of concepts.

The results don't show any real showstopper but just topics, which require care:

- life duration (very different from space use specifications)
- redundancy strategies
- maintainability

These points need to be treated for more detailed studies.

Hydrogen Regulating Valve Feasibility and Concept Analysis

SNECMA propose four concepts of valves to control fuel flow supplied for the CRYOPLANE project compatible with main characteristics already defined.

For these concepts, prototypes have already been achieved or are in progress.

These four concepts and their main advantages and drawbacks are described in the Table below.

**Final Technical Report
CRYOPLANE
System Analysis
(Publishable Version)**

Hydrogen Regulating Valve Options

	Main advantages	Main drawbacks
1. High gear ratio actuator with cylindrical obturator	<ul style="list-style-type: none"> - Precision - Simple electronics - Price 	<ul style="list-style-type: none"> - Leakage - Limited response time
2. Rotary valve with low gear ratio actuator	<ul style="list-style-type: none"> - Response time - Good compatibility with regulation 	<ul style="list-style-type: none"> - Leakage - Complexity of electronics
3. Direct rotary valve without external shaft	<ul style="list-style-type: none"> - Minimum leakage - Precision - Good compatibility with regulation 	<ul style="list-style-type: none"> - Complexity of electronics
4. Fully redundant linear valve	<ul style="list-style-type: none"> - Complete redundancy - Simple electronics 	<ul style="list-style-type: none"> - Precision - Leakage - Necessary scale adaptation

Technically, the third solution (valve without external shaft) seems to be the most interesting as solving the problem of leakage is the major concern.

As the first solution is quite simple and cheap, it should be examined if leakage and limited response time may be acceptable.

The second solution may be chosen if response time is the most important criterion.

The fourth solution may be examined only if total redundancy is necessary.

To choose the most appropriate concept and optimise the valve, requirements have to be refined and hydraulic conditions completed.

Final Technical Report CRYOPLANE System Analysis (Publishable Version)

Heat Exchanger



Figure 21: Heat Exchanger

weight from 10.7kg per engine for the A321 to about 33.2kg for the Very Large Long Range Aircraft. The heat exchanger can be designed to have little effect on the engine installation and therefore it is not a technical show stopper for a CRYOPLANE."

Since the hydrogen is stored as a liquid at about 20K, it must be heated and evaporated to a gaseous condition near the engine before it can be injected into the engine combustors. It will need to be a gas at about 150K to 250K temperature. Studies have been completed by SNECMA which show that a good solution is a tube wrapped round the engine jet pipe. (Picture 20) Sufficient heat is available and

there is only a very small loss of engine thrust due to the lower temperature of the exhaust gases. The tube heat exchanger varies in

Task 4.6 Engine Controller

(Diehl Avionik Systeme, Ueberlingen, Germany).

The main object of the task "Engine Controller" was the definition of a basic concept of a new hydrogen fuel control system.

This hydrogen fuel control system consists of two major parts. These parts are distinguished according to the two states of the hydrogen fuel they use. In "Part 1" the hydrogen is in the liquid state, while in "Part 2" it is transformed by the heat exchanger into the gaseous state. The Part 2 design of the hydrogen fuel system is primarily based on the hydrogen fuel system of the "Fachhochschule Aachen" (FHA), which meters gaseous hydrogen to a GTCP 36-300 APU and is controlled by a DAV engine controller since 1992.

The functionality, the components and the interface to the Electronic Engine Controller (EEC) of the new hydrogen fuel control system have been compared with typical kerosene Auxiliary Power Unit (APU) fuel control system. Derived from the results of this comparison, the new requirements of an engine controller have been defined.

Both fuel control systems have been discussed with other partners of Work Package 4 during a meeting at SNECMA in Vernon, France.

The comparison between a conventional kerosene fuel control system and a hydrogen fuel control system shows that the hydrogen fuel control system has a more extensive functionality and more system components. The interface to the Electronic Engine Controller will also increase.

Final Technical Report CRYOPLANE System Analysis (Publishable Version)

The additional EEC interface functions, for a hydrogen control system, are:

- Heat Exchanger Torque Motor
- Heat Exchanger Position Sensor
- Fuel Metering Valve Position Sensor
- Oil Filter Differential Pressure Switch
- Relief Valve Pressure Switch
- Additional pressure, temperature and fuel flow inputs
- Pump Speed Command
- Pump Speed Input

The additional EEC control functions are:

- More extensive APU speed control under consideration of additional pressure, temperature, and fuel flow input signals
- Heat Exchanger Temperature Control
- Fuel Pump Speed Control

If the safety assessment process of the H2 fuelled aircraft does not establish more severe safety requirements for the propulsion system, then the current architecture of the APU controller, the main engine controller could be retained. The general system design is defined below:

- APU controller
 - Single lane system
 - Independent over-speed protection
- Main engine controller
 - Dual lane system
 - Independent over-speed protection

Task 4.7 APU (Auxiliary Power Unit (Fachhochschule Aachen, Germany)

Please see Task 4.4 above.

Task 4.8 Propulsion System for Validator Aircraft (Airbus Deutschland GmbH, Hamburg, Germany)

Flight Test Proposal

A medium time-scale opportunity to validate the CRYOPLANE technology with limited risk is the integration of a hydrogen supplied APU in a conventional kerosene supplied aircraft with a relatively regular flight mission. An aircraft with a relatively regular flight mission which might be available for AIRBUS and which does not use the APU as an essential device, is the A300-600ST (Beluga). Beluga could be

Final Technical Report

CRYOPLANE

System Analysis

(Publishable Version)

equipped with a hydrogen-fuelled LH₂ APU. The APU installed in the A300-600 is a GTCP 331-250. This APU-type would be modified for operation on LH₂ and would be installed in the a/c A300-600ST (Beluga).

This will require the design, build and development of a representative hydrogen system, consisting of all appropriate components, such as tank, pumps, valves, controller, leak and fire detection, etc. to allow a hydrogen powered APU to perform all typical functions of a conventional aircraft APU. There would, of course, also need to be a suitable ground based hydrogen fuel supply system in at least one airfield.

The purpose of the Task 4.8 is to study the feasibility of a hydrogen (LH₂) supplied APU on a conventional aircraft with kerosene supplied main engines. Full details are given in TTR4.8-7. A brief summary follows below.

Background - APUs tested with hydrogen fuel

The conversion of a kerosene APU to a gaseous hydrogen (GH₂) APU has been performed successfully by FH Aachen (see Tasks 4.4 and 4.7 above). A new design of Combustion Chamber (Micromix), developed by FH Aachen for operation on hydrogen, has been integrated in a GTCP 36-300 APU (at FH Aachen) and tested. It has revealed the potential of reducing the NO_x-emission in comparison with the original kerosene combustion chamber by up to 80 %.

Requirements and Design Criteria for the APU

The overall APU system configuration in the validation tests can basically remain unchanged; however, some components have to be re-designed or newly developed. The primary design targets are to achieve a safe and reliable operation on LH₂ and to minimize emissions of NO_x.

Main APU Engine Hardware Changes

Heat Exchanger: A new heat exchanger is required to pre-heat the cryogenic hydrogen before it is injected into the combustion chamber in order to achieve a stable combustion process.

Control and Metering System: Control and metering of the hydrogen is carried out by a Hydrogen Fuel Control Unit (HFCU), which replaces the original Fuel Control Unit. It is located between the heat exchanger and the engine combustion chamber.

Combustion Section: The combustor needs to be completely changed relative to kerosene. The primary design target for the H₂ combustion section is to realize low emissions of NO_x and to facilitate stable operation over the whole power range. The new combustion design should be based on the FH Aachen „Micromix“ design.

Installation and Integration of Hydrogen Fuelled APU

Final Technical Report CRYOPLANE System Analysis (Publishable Version)

Key considerations for the engine are:

Fire protection, detection and extinguishing: H₂ flame is not visible, making optical sensing difficult. Good ventilation is the key to avoid a flammable mixture being formed. Extinguishing a H₂ flame is difficult due to its buoyancy. For a hydrogen fire no dedicated fire extinguishing system is recommended. A hydrogen fire should burn down by itself. For the APU engine the existing fire extinguishing system is sufficient; see below for aircraft system requirements.

Suspension, Intake, Exhaust, Compartment

A weight increase for the hydrogen APU is expected due to the modified combustion chamber and added heat exchanger. The suspension system has to be designed to match the increased APU weight. It is required to achieve a drop-in solution. Protection of personnel is required.

Fuel supply

The fuel supply from the fuel tank to the APU will be driven by pumps via one single supply line. The LH₂ feed line connects the LH₂ fuel tank with the heat exchanger entry. For the LH₂ feed line vacuum insulation shall be used. Surfaces of pipes, tanks and especially connectors containing liquid hydrogen could cool down below the boiling point of air/oxygen. Condensation of air/oxygen stemming from the surrounding air is a safety hazard and has to be avoided by insulation.

Fuel supply control unit

This could be incorporated into the APU control unit.

APU control unit

Control and metering of hydrogen under the given circumstances is a complex task and differs from measuring kerosene, since the hydrogen is metered and injected into the combustion chamber in a compressible gaseous state. The actual pressure and temperature have to be measured continuously at multiple locations and the control unit has to calculate the appropriate positions of the GH₂ control and metering valves in order to compensate compressibility effects.

Another function of the control unit is to control continuously the flame inside the combustion chamber. However, it has to be evaluated, if a temperature sensor or ultraviolet sensor is preferred. In the case of an extinguished flame the LH₂-supply shall be shutdown immediately preventing unburned hydrogen to re-ignite at hot surfaces, which could lead to the engine's destruction due to the high explosion speed of hydrogen.

Final Technical Report CRYOPLANE System Analysis (Publishable Version)

Engine Operation

Before engine start-up, the piping system should first be purged with an inert gas. After this it should be cooled down by means of cold GH_2 circulation, preferably from a liquid reservoir. Aircraft batteries perform the electrical supply of the APU tank pump.

For cold APU starting there is no exhaust heat for the heat exchanger. The APU could be started with GH_2 supplied from the top of the LH_2 -tank or an electric heating for LH_2 (electrical supply is performed by aircraft batteries).

In normal operation, the hydrogen APU should be operated as a non-essential APU for the validation trials. To limit the amount of hydrogen a 3 hours APU operation time is proposed between re-fuelling.

APU related fuel tank

A tank volume, which achieves a 3-hour operation of the APU, is assumed. It is approximately a 1 metre sphere.

Typically tanks are not located in the impact area of the turbines and have to be strictly separated from the cabin. From a safety point of view a tail tank aft in the rear fuselage is a well-chosen location for a hydrogen tank. Gaseous hydrogen can be released into the outside during flight without jeopardizing possible passengers or aircraft components. For the A300-600St (Beluga) the aft cargo compartment section 19 is preferred for the hydrogen tank of the CRYOPLANE APU validator.

During normal operation the pressure in the tank is usually $p = 1,2 \dots 2,0$ bar
The tank in operation is filled up with saturated liquid hydrogen at the pressure range defined above, corresponding to a normal operating temperature range of $T = 20,2 \dots 22,3$ K

To achieve the required thermal insulation the tank should have double walls and vacuum space between inner and outer vessel. The space is filled with super insulation. The quality of insulation shall be such, that boil-off losses will be avoided as far as possible.

Compartment

The design of an installation box or container as a compartment for most of the hydrogen system is recommended. Ventilation and detection are more centralized and limited to a certain volume. Improved disassembly of the hydrogen system is facilitated, which keeps the Beluga operational in case of hydrogen system failures.

Final Technical Report

CRYOPLANE

System Analysis

(Publishable Version)

A container or compartment of about 1,4m x 1,4m x 2m dimensions should be able to incorporate most of the hydrogen system. A first estimation of the additional weight for the hydrogen system leads to 1650 kg including 250 kg LH₂.

Overall Conclusion of WP4 (Propulsion)

Conventional kerosene-fuelled turbofan engines can be modified to burn hydrogen. The turbo-machinery would be virtually unchanged but the combustor must be redesigned and the fuel control system changed. A heat exchanger must be added to vaporise the hydrogen fuel.

Conventionally based hydrogen-burning engines run 30K – 50K cooler for a given thrust than their kerosene fuelled parents and give a 1% to 2% advantage in energy based specific fuel consumption. They do not emit any Carbon Dioxide (CO₂).

The cold sink provided by the hydrogen fuel can be utilised in unconventional forms of turbofan engines. Such engines give small but useful performance improvements but have extra mechanical complication. Nevertheless they can improve the aircraft Direct Operating Cost.

New computer codes for simulation of hydrogen powered engine performance have been developed and are available at Cranfield University, UK and at U.P. Madrid.

The key component technology requiring development for the engine is the combustor. Testing of a “Micromix” combustor on an APU engine has been under way at FH Aachen for some while. Measurements show up to 80% reduction in NOx emissions relative to kerosene. However, although this programme is very successful, in order to achieve a combustor suitable for flight-testing, more work is required.

The hydrogen fuel supply system in the aircraft requires special attention; however, it should not pose technical difficulties because the technology exists already in the EU hydrogen rocket programme (SNECMA, Vernon). Pumps and valves are key components.

The engine controller can be based on the one supplied by Diehl Avionik, Uberlingen to FH Aachen for their APU tests. It will be more complex than the system for control of kerosene but the technology exists.

To validate an engine Airbus Deutschland proposes the use of a hydrogen-fuelled APU. The APU and its associated systems would need to be designed and developed. This will need firstly ground tested and later flight tested in an A300–600ST (Beluga) aircraft, as a non-essential APU.

Final Technical Report CRYOPLANE System Analysis (Publishable Version)

Overall, the aircraft safety assessment demonstrated that the existing paragraphs of the safety and airworthiness regulations can stay in place for any of those accidental events. Technical solutions and the interpretation of these regulations can be adapted in order to meet a higher or at least the same level of safety.

In general terms, the conclusion is that

Hydrogen poses its specific safety aspects to be considered in design and operation. However, the overall safety level will not be worse than for kerosene aircraft.

A number of subjects were identified which need tests for final clarification, such as

- the release of large amounts of liquid and gaseous hydrogen
- the formation and vaporization of large liquid pools.
- the dispersion of large hydrogen clouds.
- the likelihood of sufficiently large free clouds to detonate.
- the results of damage to storage tanks (drop, fire, force, crush, shots etc.).
- the material embrittlement due to the low temperature in case of release.
- the suitability of valves, connections, seals, materials etc. for cryogen temperature.
- the accumulation of oxygen inside the fuel system.

Depending on the configuration of the aircraft it would be of special interest to perform tests, which show the case of a Liquid Hydrogen tank being hit by some projectile, be it a bullet or a piece of debris from an uncontained engine failure. If such test would result in a catastrophic scenario, tanks would have to be arranged outside of the burst area. Better understanding of this aspect hence is highly desirable. Large-scale tests with tanks of aviation typical design, support, and position relative to the passenger cabin, are high on the priority list for future research work.

Safety of infrastructure/airport operation again needs special attention. Hydrogen production at the airport needs adapted regulations and safety standards for storage and handling. The difference in size for particular components is a safety challenge that needs to be carefully considered. The released amount of hydrogen in the area of the airport must be kept at low levels at all times (e.g. through shut-off valves). Particular measures must be taken to prevent domino effects (e.g. by maintaining appropriate safety distances among critical components and sub-systems) and to keep potential accidents confined. Finally, through the combination of safety measures identified above the presence of hydrogen at the airport must not have dangerous effects on surrounding installations

Final Technical Report CRYOPLANE System Analysis (Publishable Version)

4.6 Work Package 6 Environmental Compatibility

Objectives

The main objective of this WP was to assess the current state of knowledge about environmental compatibility of liquid hydrogen as an aviation fuel taking into account both production of fuel and fuel use in aircraft, in comparison to kerosene, which is currently used. To meet this main objective the WP was divided in nine well-defined tasks with clear objectives.

Task 6.1 Work Package Integration and Leadership

The objective of this task was to coordinate by organizing meetings and workshops the work performed under this WP and to integrate and report the results achieved to the project's coordinator.

Task 6.2 Overall Effect of Gaseous Emissions

The objective of this task was the estimation of the qualitative difference between the global climate impact of a hydrogen fuelled air fleet and a kerosene fuelled air fleet with respect to the respective overall (i.e., global mean) gaseous emissions.

Task 6.3 Effects of contrails on climate

The objective of this task was a quantitative estimation of the differences in key parameters determining the specific radiative effects of conventional and cryoplane contrails, respectively.

Task 6.4 Effects of contrails and clouds upon UV-radiation and Photochemistry

The objective of this task was to quantify changes to the photo dissociation rates of certain key species due to changes in the radiative transfer, caused by cirrus clouds and contrails generated from the use of hydrogen as fuel, compared to kerosene.

Task 6.5 Simulation of regional effects of aviation

The objective of this task was to quantify on a regional scale the improvement in environmental impact of aircraft emissions on the atmospheric composition that results from changes in fuel use from kerosene to hydrogen.

Task 6.6. Global effects of gaseous emissions and contrails

The objective of this task was to simulate characteristic global patterns of the radiative forcing of aircraft related changes in atmospheric trace gases and contrails with special emphasis on respective differences between cryoplane based air traffic and conventional air traffic.

Task 6.7 Global mean climate response from transition scenarios

The objective of this task was to provide simplified assessments of transition scenarios a one-dimensional linear response model.

Final Technical Report CRYOPLANE System Analysis (Publishable Version)

Task 6.8 Life Cycle Analysis (LCA)

The objective of this task was to compare the environmental effects of hydrogen and kerosene over the full life of the fuel.

Task 6.9 Conclusions of validator aircraft

The objective of this task was to define possible requirements for a design of a validator aircraft, by determining which key questions of the WP 6 could be solved experimentally only i.e. by means of a validator aircraft.

Results

Overall effects of gaseous emissions

The gaseous emissions crucial for a sensible comparison of the global mean climate impact of kerosene fuelled aircraft and cryoplanes are CO₂, NO_x (influencing ozone and methane in the atmosphere) and water vapour. In a preliminary assessment of the potential environmental gain of the cryoplane technology a linear response model was applied to extremely idealised transition scenarios, comprising the impact of gaseous emissions and contrails to the climate system. A linear growth of ozone (and methane) concentration change with aircraft NO_x emission was assumed. New simulations with a 3D climate model using higher vertical resolution confirm that the linear dependence between ozone concentration increase and NO_x emissions can still be used for estimates of global climate change between 2015 and 2050. This also allows a determination of atmospheric ozone concentration changes for cryoplane traffic through linear scaling with the reduction factor for the NO_x emissions.

The tropopause radiative forcing estimates for aircraft related ozone and methane changes at the 2015 time horizon amount to 0.054 Wm⁻² and -0.036 Wm⁻², respectively, for conventional air traffic, and to 0.005 Wm⁻² and -0.004 Wm⁻² for a minimum estimate of cryoplane air traffic, if it is assumed that the NO_x emissions from LH₂ engines are up to 90% (ref. 3) smaller.

If the existence of higher climate sensitivity due to atmospheric ozone changes were confirmed, this would mean an even larger decrease of aircraft climate impact as a result of reduced gaseous emissions by a LH₂-fuelled air fleet.

Concerning the climate impact of gaseous water emissions this was found to be negligible in either case and it is unlikely that the enhanced water vapour emissions caused by a switch to the cryoplane technology will induce a substantial contribution to the total climate impact from these aircraft.

Effects of contrails on climate

Persistent contrails have been considered to be one of the most important contributors to the net climate impact of air traffic and the effect is quantified to grow by about 50% due to the mean contrail coverage increase in a cryoplane scenario. This would

Final Technical Report CRYOPLANE System Analysis (Publishable Version)

enhance the contrail radiative forcing accordingly. However, the microphysical properties of a cryoplane contrail are different. Microphysical simulations of two extreme cases (very warm, -47°C , and very cold, -62°C) were performed using the 2-D microphysical model MESOSCOP (ref. 4). They show that cryoplane contrails are optically thinner under the same ambient conditions, as less but larger particles form during the contrail development. They also show that a substantially reduced persistence of cryoplane contrails due to more efficient sedimentation of ice crystals is unlikely.

There are two microphysical parameters used by a global climate model to define the optical depth of a contrail, the ice water path (IWP) and the effective ice crystal radius r_{eff} . The IWP values are quite similar for both types of contrails. Based on further MESOSCOP simulations for a wide range of possible ambient parameters, it was found that the effective radius in cryoplane contrails is larger by a factor of about 3.3, compared to that in conventional contrails (Figure 22). Optical depth is reduced by a similar factor.

Representative numbers for the difference of radiative impact in the conventional and the cryoplane scenario have been obtained from three simulations performed with the 3D global climate model on the basis of an aircraft emission inventory for the 2015 time slice. It has been assumed that all air traffic in 2015 is operated either by kerosene or by LH_2 fuelled aircraft. For the conventional scenario the resulting global mean net radiative forcing is $9.8 \cdot 10^{-3} \text{ W/m}^2$. This value increases to $16.5 \cdot 10^{-3} \text{ W/m}^2$, if only the increase of contrail formation probability for cryoplanes is taken into account. However, if the changes in optical properties are also considered a radiative forcing of $8.0 \cdot 10^{-3} \text{ W/m}^2$, about 15% *smaller* than the reference value, is estimated for the cryoplane case.

**Final Technical Report
CRYOPLANE
System Analysis
(Publishable Version)**

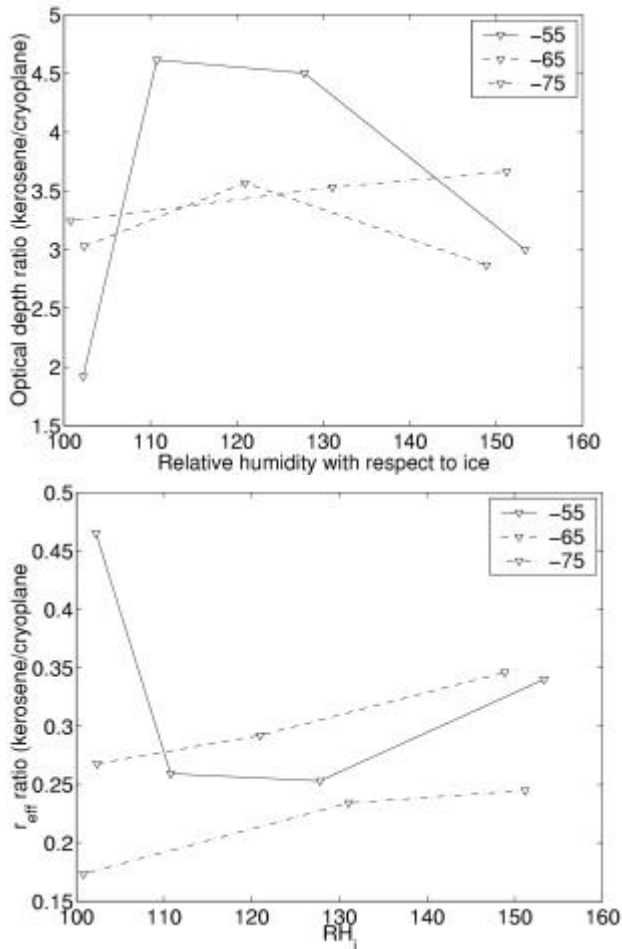

Figure 22: Ratio (kerosene/cryoplane) of optical depth (left) and mean effective crystal radius (right), respectively, calculated for each ambient condition parameter pair of temperature (-55°C; -65°C; -75°C) and humidity.

Effects of contrails and clouds upon UV-radiation and photochemistry

A sensitivity analysis was performed, using a radiative transfer model, for the expected changes in the photolysis rates of ozone and nitrogen dioxide. These changes are perturbations in the radiative transfer, caused by contrails and cirrus clouds generated from the potential use of hydrogen fuel by the aviation. First the model has been validated and then the results were compared to those, which correspond to contrails from conventional (kerosene-fueled) aircraft

Predicted from CTM models ozone changes for the year 2050 are responsible for the main perturbation (10% decrease) of $J(O^1D)$ but don't affect $J(NO_2)$.

For the same amount of total ozone the existence of a cirrus cloud and/or contrail at an altitude of 10-11km introduces relative to the clear sky case a small increase of photolysis rates below the clouds/contrail and for the case of $J(O^1D)$ a decrease at the Earth's surface.

Final Technical Report CRYOPLANE System Analysis (Publishable Version)

The additional perturbations induced to the photolysis rates from contrails are larger for the kerosene contrails compared to the ones induced by LH₂ contrails, since they are expected to have smaller optical depths.

Cirrus cloud cover data for almost two decades (1984-1998) were analyzed using the ISCCP D2 (ref. 4) data set. Isolation of natural fluctuations in global cirrus cloud cover show that there is positive correlation of 0.6 between fuel consumption from aviation and changes in cirrus cloud cover over areas with high traffic (Figure 23).

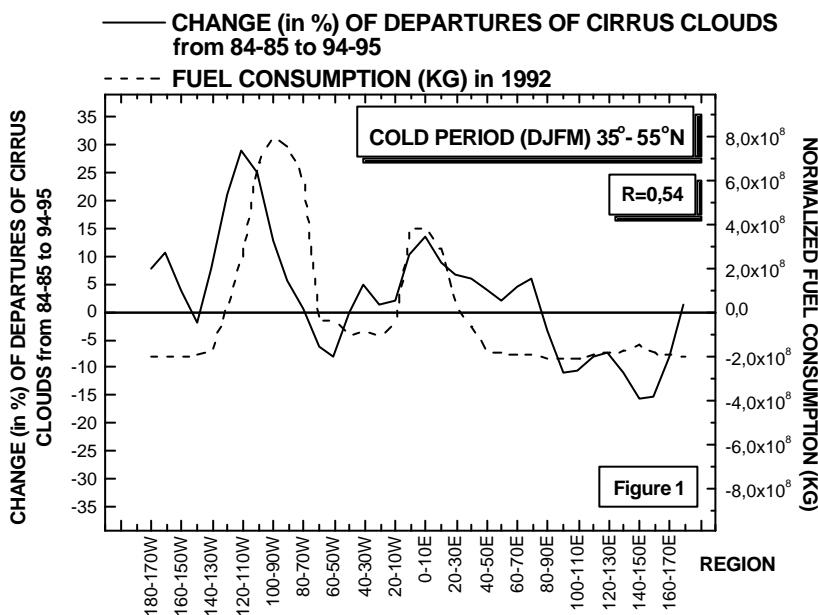

Figure 23. Changes in cirrus cloud cover versus fuel consumption as a function of latitude for the 35°-55°N belt.

Simulation of regional effects of aviation

Local perturbations in Noy. (reactive nitrogen compounds, including nitric acid) and ozone in the tropopause region over Scandinavia have been assessed along with their seasonal variation. For the same region the local effects of H₂O emissions have been assessed. For the perturbation studies the OSLO CTM-2 (ref. 4) model has been used, which has been thoroughly validated especially for the tropopause region.

Subsonic aviation in the year 2000 is found to have only little effect upon the stratosphere, but leads to significant increases in zonal-mean NO_y and ozone in the tropopause region of the Northern Hemisphere. The location and magnitude of maximum perturbations exhibit a distinct seasonal variation. Maximum absolute increases in ozone are modelled at about 11km. Over Scandinavia a clear seasonal dependence of the aircraft-induced ozone change is seen with maxima in May-June-July.

Final Technical Report CRYOPLANE System Analysis (Publishable Version)

The lifetime of methane will decrease as a result of enhanced OH levels. It has been estimated on an annual basis that the lifetime of methane will decrease by 0.7% from the surface up to 300 hPa.

The increase in water vapour due to aircraft and the resulting radiative forcing has been calculated for the year 2015 for different types of aircraft and different assumptions on the tropospheric lifetime of aircraft-emitted water vapour, $\tau_{\text{H}_2\text{O}}$. Due to cryoplanes maximum annual-mean perturbations are in the range 200 – 300 ppbv.

Despite the lower total water vapour emission, the scenario including supersonic (kerosene) aviation leads to a more pronounced effect on lower stratospheric water vapour, while subsonic kerosene aircraft have only a minor impact.

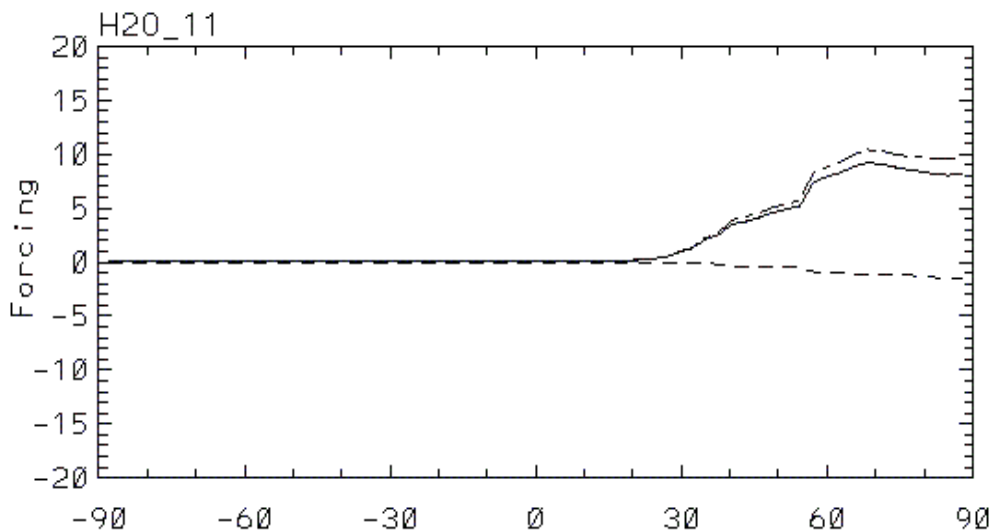

Figure 24. Zonal-mean radiative forcing for a cryoplane scenario in April 2015 [10^2 Wm^{-2}] over latitude. The dashed lines depict the short-wave radiative forcing, the dash-dotted lines the long-wave radiative forcing, and the solid lines the total radiative forcing.

Averaged over the considered seasons the global-mean radiative forcing is calculated to be in the range 0.0043 to 0.0065 Wm^{-2} for the cryoplane scenarios, where the tropospheric $\tau_{\text{H}_2\text{O}}$ is calculated from meteorological data. The corresponding value for subsonic kerosene aircraft is relatively small amounting to 0.0026 Wm^{-2} . The case including supersonic aircraft yields much larger radiative forcing near 0.05 Wm^{-2} , because the H_2O perturbation is larger and located at a higher altitude.

The main uncertainty of this study, not unlike other CTM studies of this type, lies in the estimation of the lifetime of aircraft-emitted H_2O in the troposphere, which may not represent the real removal of excess water vapour by the hydrologic cycle. However, even in the short lifetime case, significant water vapour perturbations are calculated.

Final Technical Report CRYOPLANE System Analysis (Publishable Version)

Global effects of gaseous emissions and contrails

Based on a climate model parameterisation for the contrail global mean radiative forcing we have found that the global climate impact of line-shaped persistent contrails is probably smaller than the best estimate established by IPCC (1999) (ref 5). Our own best estimate for conventional air traffic is $9.8 \cdot 10^{-3} \text{ W/m}^2$ and $19.4 \cdot 10^{-3} \text{ W/m}^2$ for a typical 2015 and 2050 scenario, respectively.

A switch from conventional to cryoplane air traffic is likely to reduce the aircraft climate impact (radiative forcing) due to contrails by roughly 20% ($8.0 \cdot 10^{-3} \text{ W/m}^2$ and $13.9 \cdot 10^{-3} \text{ W/m}^2$ in the 2015 and 2050 simulations, respectively). The reason is the larger mean effective particle size in cryoplane contrails, leading to a reduction in emissivity and optical depth that overcompensates the effect of increasing cloud coverage for cryoplanes. The change of radiative forcing is quite different in different geographical regions (Figure 25). If the size of ice particles in contrails were substantially lower than hitherto assumed, a qualitatively different assessment of the cryoplane contrail effect cannot be excluded. In the latter case, much will depend on the range of possible ice particle shapes in persistent contrails.

Our studies do not account for possible changes in the background climate up to 2050 (global warming). Also not yet included is the problem of a specific climate sensitivity (different from that of CO_2) for contrails. This possibility has to be studied by much more extensive climate model simulations than have been performed in CRYOPLANE.

Concerning radiative forcing contributions from ozone, methane, and stratospheric water vapour changes due to air traffic, there appears to be no need for a thorough revision of the key numbers documented in IPCC (1999) (ref. 5) and in Marquart et al. (2001) (ref 6).

Final Technical Report CRYOPLANE System Analysis (Publishable Version)

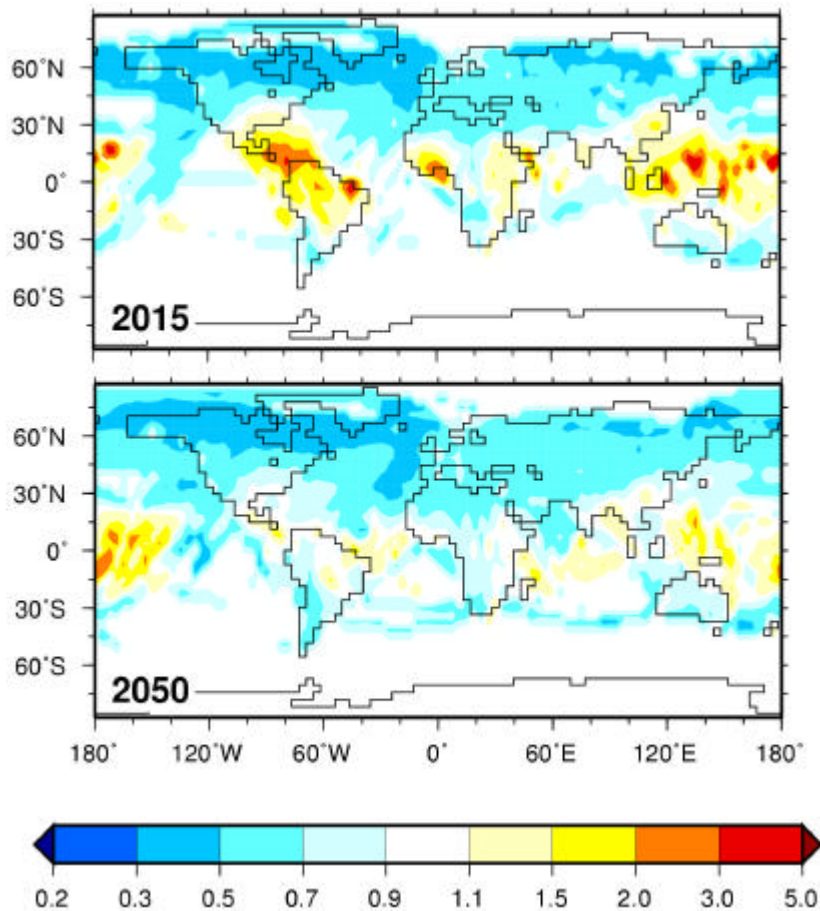

Figure 25. Ratio of the net radiative forcing of cryoplane contrails and the respective value for contrails from conventional aircraft (see Fig. 22). Top panel relates two scenarios for an air traffic density expected for year 2015; bottom panel relates two respective scenarios for 2050 (see text). Red (blue) areas indicate those regions, where cryoplanes cause a larger (smaller) contrail climate impact.

Global mean climate response from transition scenarios

Estimating the global mean climate impact change resulting from a realistic transition to cryoplane technology between 2015 and 2050 with a linear climate response model, we determine a typical value of about 25% reduction in radiative forcing at the 2050 time slice with tendency to increasing reduction thereafter.

Depending on the speed of the transition to cryoplanes best estimates range between 16% and 29% climate impact reduction (Figure 26). Due to inherent scientific uncertainties with respect to the individual climate impact contributions of the various effects considered here (CO₂ and NO_x emissions, contrails), the respective uncertainty range widens to between 14% and 40% at 2050.

Further sources of potential importance (Contrail cirrus, CO₂ emitted during the production process) could not be quantified here, but can be included in the assessment as soon as the level of scientific understanding has improved.

Final Technical Report CRYOPLANE System Analysis (Publishable Version)

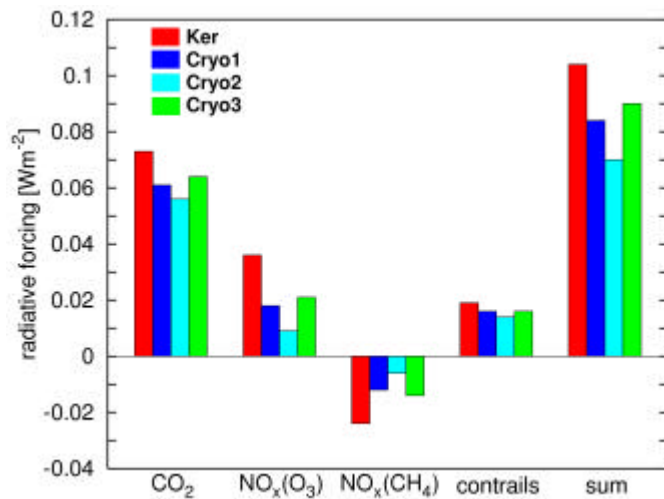

Figure 26: Radiative forcing (in W/m^2) of CO_2 , NO_x (either due to ozone or methane changes), and contrails to be expected at year 2050 for a conventional aircraft increase scenario (Ker) and three different transition scenarios to cryoplanes (Cryo1/2/3). The respective best estimates for the various contributions are shown. The columns represent global mean values, as calculated by means of a linear response model. The rightmost panel shows the sum of all displayed components, not including further contributions from soot and sulphur aerosols as well as water vapour increases.

Environmental effects of fuel production, distribution and use - Life Cycle Analysis (LCA)

LCA has been carried out to investigate the environmental and energy aspects of different types of aviation fuels. The life cycle of kerosene includes the extraction and transport of crude oil, the refining process, distribution and handling of the aviation fuel and finally the combustion in jet engines. For the life cycle analysis of LH_2 as aviation fuel different production scenarios were considered. These include hydrogen produced from steam reforming of natural gas as well as from renewable energy sources (solar energy, wind power, hydro power, biomass). Certain environmental impacts were determined using the inventories created for the life cycle analysis. These include global warming potential, ozone depletion effect, acidification effect, eutrophication effect and winter-smog. Initially the production phase of aviation fuel was compared. Figures 6a-d compare the equivalent emissions of CO_2 , SO_4 , PO_4 and SMP for the various fuel production phases

Final Technical Report CRYOPLANE System Analysis (Publishable Version)

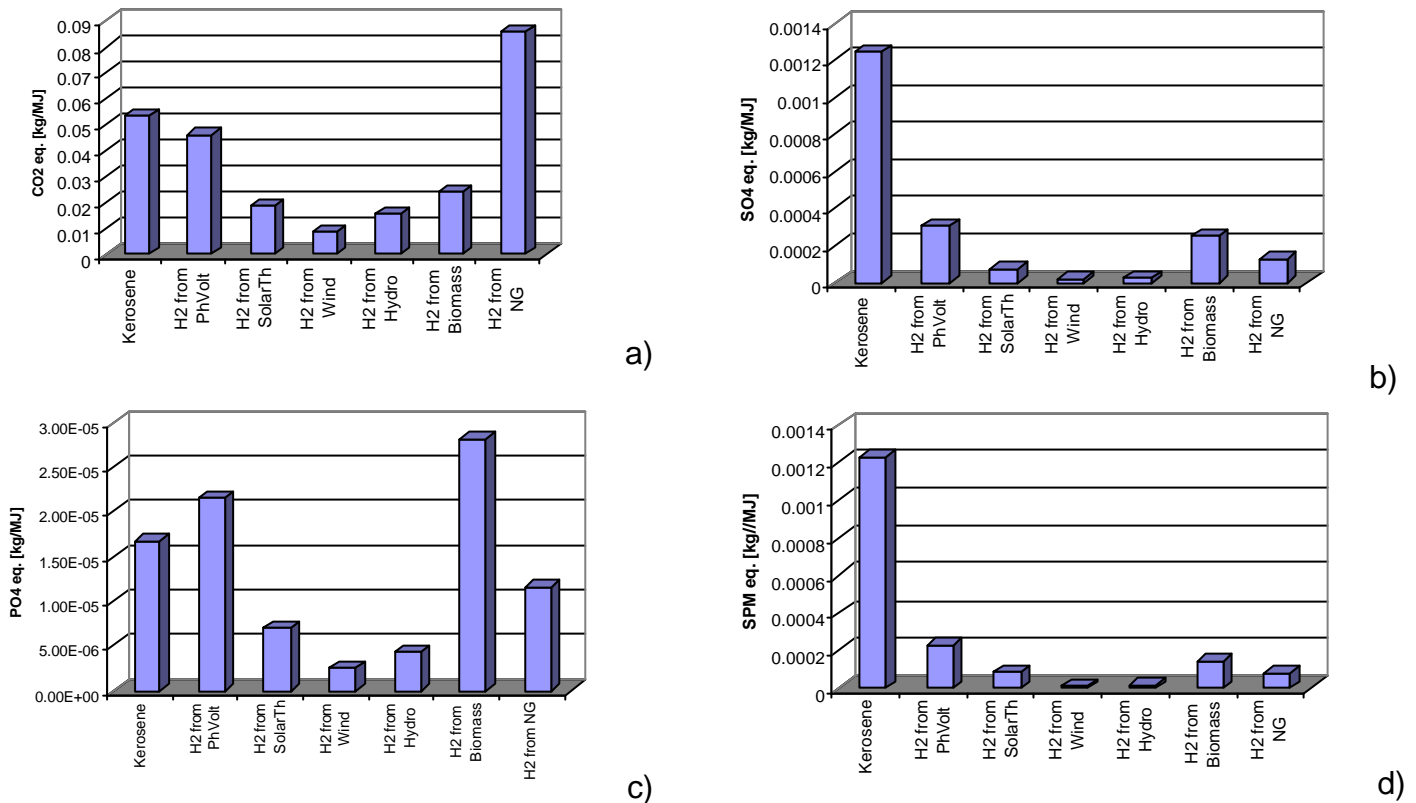

Figure 27: Equivalent emissions of aviation fuel production.

Next the fuel consumption step was assessed in order to present the contribution of this phase to the total life cycle of the aviation fuel system. For this purpose 8 representative Airbus aircraft types were considered including both long and short-range flights. Figure 28 shows the equivalent emissions of CO₂ and SO₄, for an A319-100 aircraft per km travelled for the various fuels.

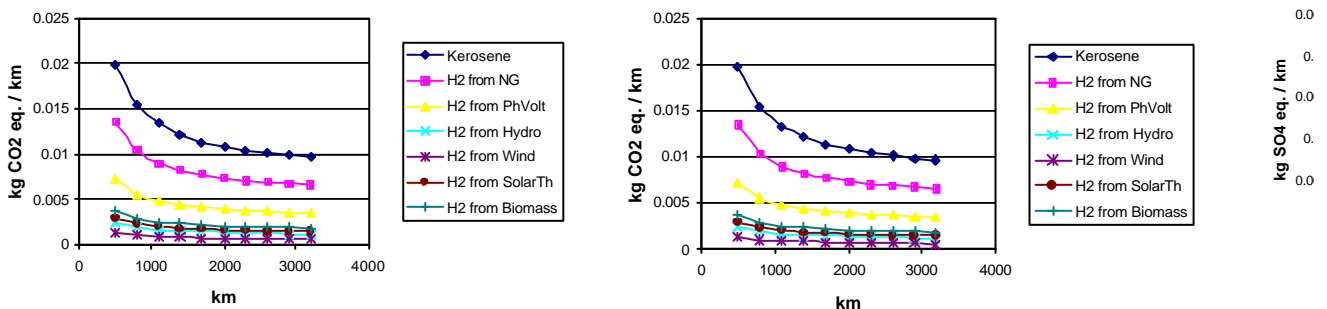

Figure 28: Life cycle CO₂ and SO₄ equivalent emissions of an A319-100 aircraft per km travelled

Although hydrogen is generally considered to be a clean fuel, it is important to recognize that its method of production plays a very significant role in the level of environmental impact. Among all aviation fuel systems, the kerosene life cycle results to the greater environmental impact. Acidification, and winter smog emissions are very high due to the extraction and refining processes of crude oil that result to the production

Final Technical Report

CRYOPLANE

System Analysis

(Publishable Version)

of kerosene. Kerosene combustion also contributes significantly to these categories according to the flight distance. Eutrophication emissions are also very high in comparison with all hydrogen production systems. High SO₂ emissions during the refining process but also high emissions of NO_x and SO₂ during kerosene combustion are an important factor to this impact category. Greenhouse gas emissions of the kerosene life cycle are also very high. However, hydrogen production from natural gas has a high contribution to the production of CO₂ eq. emissions. Hydrogen production from photovoltaic energy presents a much lower contribution, which is mainly caused by the production of the photovoltaic modules. Hydrogen production from wind and hydropower energy is the least polluting system even for long distance transport. Equivalent emissions in all impact categories are very low. Biomass and solar thermal production of hydrogen also lead to very low emissions.

Validation of Theoretical Results

For kerosene-fuelled aircraft, models for the calculation of the impact on the atmosphere by the combustion products in flight level have already been established and proven by flight test data. Comparison of the impact on the atmosphere of H₂ fuelled Aircraft have been done based on similar calculation models. In order to prove this data a validation by flight test with a H₂ fuelled power plant would be necessary.

A validator aircraft or a simulator could be used to get information about environmental and climate impact of cryoplane, which cannot be produced by models as, number of condensation nuclei in the exhaust plume and consecutive micro-physical, optical radiative properties of contrails.

4.7 Work Package 7 Fuel Sources and Infrastructure

Following aspects have been considered under WP7

Task 7.1 Work Package Integration and Leadership (Techn. Univ. Hamburg - Harburg)

Task 7.2 Review of Conventional Hydrogen Production Processes (Techn. Univ. Hamburg - Harburg)

Task 7.3 Hydrogen Production Processes Based upon Renewable Energy (JRC, Inst. for Systems, Informatics and Safety)

Task 7.4 Review of Liquefaction Processes (L'Air Liquide)

Task 7.5 Infrastructure for Production, Storing and Distribution at Airports (Linde AG)

Task 7.6 Aircraft Ground Operations
(Cranfield Univ., CoA)

Final Conclusion

- In the transition period from kerosene to liquid hydrogen fuelled aircraft the cryogenic fuel can be produced from fossil fuels, liquefied and distributed on airports without restrictions to capacity and aircraft specifications.

**Final Technical Report
CRYOPLANE
System Analysis
(Publishable Version)**

- Use of renewable energies for the LH2 chain remains mandatory in respect of avoidance of emissions in a final stage
- Use of renewable energies is crucial for huge capacities required in liquid hydrogen fuelled aircraft and for high cost
- CO2 sequestration may offer an option to cope with GWP (Global Warming Potential)
- Ground operations (turnaround/maintenance) for CRYOPLANE realizable without major modification for existing ones

Review of Conventional H2 Production Processes

Introduction

Among several ways of classification, conventional hydrogen production process can be arranged in two groups:

- (a) generation as by-product
- (b) generation as primary product

The table below gives an overview of production techniques and output (*Figure 29*)

Production technique:	World production (10 ⁹ Nm ³ /a)
Primary product	
Reforming of natural gas & naphtha	190
Partial oxidation (gasification)	120
By-product	
Refinery industry	90
Coal refinement (coke oven gas)	50
Petrochem. industry	33
Chlor-alkali electrolysis	10
Others	7
Total	500

Figure 29: Hydrogen production: Techniques and output

Summary

The review of conventional hydrogen production processes shows that the huge demands for hydrogen is to be met by plants especially build for hydrogen production. By-product hydrogen from the refinery industry or other processes like the chlor-alkali electrolysis will - if at all - only play a minor role at single sites.

It turns out that methane steam reforming is the most favorable process in terms of economics, reliability and environmental aspects. Other processes that sound promising from a theoretical point of view like the so-called Kvaerner (ref. 8) process are not fully controlled yet so that they cannot be considered as alternative at present. This might change in future in case there is major progress.

Final Technical Report CRYOPLANE System Analysis (Publishable Version)

The determination of emissions from hydrogen production – considered to be the most important among all environmental aspects – is very difficult. Firstly, the great variety of process designs does not allow the calculation of one “true” figure. Additional processes like carbon dioxide removal from the flue gas can reduce emissions considerably.

Secondly, the choice of system boundaries decisively influences the final result. Unfortunately, no data for many up- and downstream processes was found in literature.

However, total emission of -0,766 kg to 15,154 kg CO₂-equivalent per kg H₂ can be given. At present, the higher value is the prevailing one.

Hydrogen costs may range between 0.85 to 1.40 Euro / kg H₂

Hydrogen Production Processes Based upon Renewable Energy (RE)

At the moment the most important driver for the use of renewables as primary energy source for the production of liquid hydrogen is their reduced global warming potential. It has been demonstrated in this study that all renewable energy sources can easily outplay fossil fuel with respect to GWP; this is equally true for all other environmental indicators assessed in the study.

The second main issue is cost. Although only ‘affordable’ and feasible technological systems are analysed herein, the economic analysis shows that RE-based hydrogen is produced at a much higher cost than the currently most widely used process, i.e. natural gas steam reforming.

Biomass gasification is deemed as being the technology that has the highest potential to compete economically with fossil based process. Although this strongly depends on the region of application this energy source certainly has also the potential to supply a considerable share of the potential hydrogen demand of an airport.

This study has not considered the introduction of market instruments including financial incentives, fiscal measures (e.g. fossil fuel, or CO₂ emission taxes) in order to maintain the transparency of the economic calculations. Clearly, if the use of hydrogen as aviation fuel would aim principally at addressing the burden of aviation on the global carbon budget, the results of this study would provide a sound ground upon which to advocate the introduction of similar measures. The combination of hydrogen as an energy carrier and primary electricity produced from renewable sources can be a viable solution to the global environmental concerns.

Emissions inventory and comprehensive assessment of emissions from alternatives in H₂ production from renewables.

Final Technical Report

CRYOPLANE

System Analysis

(Publishable Version)

This is a study of the present technologies and of innovative productions paths for hydrogen production based upon renewable energy. They have been examined by carrying out Life Cycle Assessment (LCA) of the technological system. The investigated process chains started with the extraction of the primary energy carrier, the transportation to the hydrogen production plant, the conversion to hydrogen and the liquefaction for use as an aircraft fuel.

The major conclusions from this study are as follows:

- Solar energy based technological systems for liquid hydrogen production including long distance energy transportation are still more favourable in terms of emissions (greenhouse gases and acidification potential) than utilising these technologies in central Europe. Solar thermal power generation has better environmental performance than photovoltaic systems.
- Wind and hydropower energy sources lead to very low emissions, even for long distance transportation.
- Biomass also leads to very low greenhouse gases but only if the biomass is produced locally to avoid transportation related emissions and with prospective gasification technologies

In addition to these findings the following factors need to be considered when interpreting the results:

Most crucial factor for the use of renewables as primary source for the production of liquid hydrogen is costs. Although only 'affordable' and feasible technological systems are analysed herein, an economic analysis is indispensable for providing clear statements for technical and consequently political decision support.

Other factors, which have not been included in the models, are the possibilities for optimisation and changes of process schemes. This might include change of configurations but also combinations of fossil and renewable systems. The employment of technological systems with fossil back-up, like it has been mentioned for solar central receiver systems, provides several advantages and it is highly recommended to consider this also in terms of emissions and cost. Especially for a transition period towards renewable based hydrogen production (and energy generation in general) this could offer a tremendous potential and is absolutely required not only to be competitive economically but also for developing the technologies.

A third issue, which has not been integrated into the study, is the consequences of higher renewable based share of energy in future. As a consequence also energy demand for construction material would be lower (positive feedback).

Last but not least it has to be mentioned that this study includes only 'material' emissions; not included are other issues like: environmental burden such as visual intrusions, local climate effects and land-use and socio-economic impacts (employment creation, public health).

Final Technical Report CRYOPLANE System Analysis (Publishable Version)

Review of Liquefaction Process.

The main Liquefaction Cycles have been reviewed like:

- Brayton cycle
 - adiabatic compression
 - isothermic expansion
- Claude cycle
 - partial liquefaction of H₂
 - compression on two different pressure levels
- Magnetocaloric liquefaction

The process and the technical data of the Kourou H₂ (ref. 7) liquefier have been made available for proving the technical feasibility of the technology on one hand and on the other hand for further cost estimations bases on existing data.

A H₂ energy mass balance has been calculated for a 50t/day H₂ case.

An overall plant layout has been developed.

A budgetary estimation for a 5t/day and a 50t/day case has been performed taking into consideration:

- H₂ Compression
- Vacuum insulated cold box
- Ultra purification
- N₂ cycle compressors
- Low pressure H₂ compressor
- High pressure H₂ compressor
- Frigorific group
- First load of NH₃ for the frigorific group
- Gas bearing expansion turbines
- LN₂ back up storage
- Interconnection piping between modules
- DCS system for the plant
- Electrical cabinets
- Engineering hours
- Fire Detection
- Erection
- Spare parts for start up
- Insurance

Conclusions

- Established AirLiquid liquefaction process for 5t/d and 50t/d LH₂ available
 - Basic engineering planning of overall liquefaction plant with 50t/d LH₂
- Capacity results in unrestricted realization and affordable budget price.

Final Technical Report CRYOPLANE System Analysis (Publishable Version)

Infrastructure, Production, Storing, Distribution at Airports

General

During a transition period hydrogen production based on fossil fuels, especially natural gas, is inevitable.

Capture and sequestration of CO₂ may reduce emission burden in the first stage of the transition phase, when reforming processes will mainly produce H₂.

Stepwise modular modification of ground installations at existing airports will be the normal case.

Site independent standardization of module - components may offer economical advantages.

Infrastructure requirements and design considerations.

- High availability of all main components in the supply chain will be required.
- Boil - off management is to be considered.
- Schedule harmonization and organization
 - o site - independent design packages combined with
 - o site - specific design packages
- Onsite LH₂ production versus LH₂ transport has to be decided case by case.
 - o small regional aircraft : LH₂ supply via trailers an option
 - o long - range aircraft : LH₂ plant directly at aircraft.

Reference scenarios have been built up on different LH₂ demand, using the implementation of small modules (5 t/d ex liquefier – appr. 3.000 ltr/h and large modules 50 t /d LH₂ ex liquefier – appr. 30.000 ltr/h).

Following an infrastructure concept, including GH₂ production, H₂ liquefaction, storage and distribution has been developed. In addition the Airport Stockholm Arlanda was selected to develop a reference scenario (50t/d LH₂ case).

The refueling technology has been laid-out and found feasible on existing technology, which has to be scaled to aircraft specific use.

Today the set of applicable Safety Requirements and their fulfillment are not yet in place.

Conclusions

Taking into consideration uncertainties both on the aircraft as well as on the infrastructure side a time schedule for having the first cryoplanes in regular airline operation can be estimated at approximately 10 (very ambitious) to 15 years (realistic).

Final Technical Report CRYOPLANE System Analysis (Publishable Version)

Aircraft Ground Operations

The following schematic block diagram (Figure 30) shows all the factors contributing to the formulation of the concept system for aircraft ground operations.

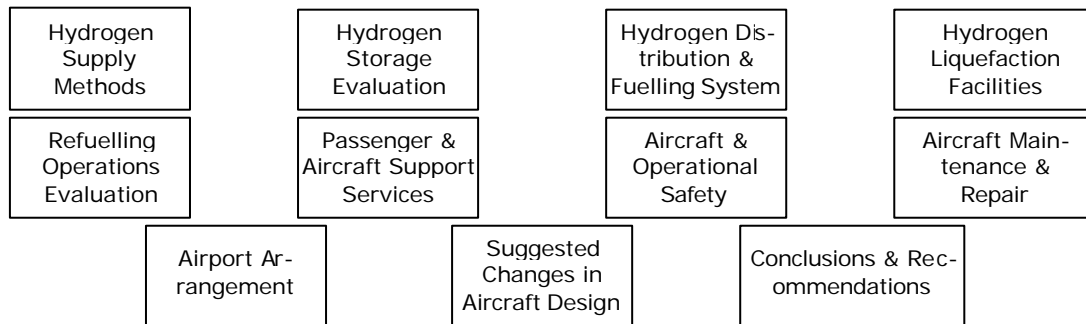

Figure 30: Schematic block diagram showing all elements for aircraft ground operation.

This is summarised by the need to identify:

- the support equipment and maintenance facilities required for a LH₂ aircraft including considerations of safety.
- potential LH₂ fuelling system concepts that can be installed and operated on existing airports.
- technical and economic impact of those systems on airport and airline operations.
- the research and technology effort required to ensure that the airport portion of an LH₂ fuelled air transport system could be made available.

Summary

So far there appears to be some obvious areas where the activity will change, and there are those areas, which will depend on the system employed as well as more detailed specifications and safety issues. After the various infrastructure and safety issues have been resolved, e.g. the type of fuel supply system, then a definition can be made of what changes will take place.

Some parts of the turnaround activity, e.g. passenger disembarking, are likely to be a consideration for the aircraft design, but for example in some configurations, the fuselage may have a low wing and tail booms surrounding the rear, and so will need new equipment. Thus the configuration may drive the need for new vehicles, e.g. very low profile to enable the vehicle to pass below the wing.

When looking at the values for minimum ignition energy, it can be seen that hydrogen will ignite with a spark one tenth of that needed to ignite kerosene fuel. However this difference becomes almost meaningless, when it is realised that the energy levels for ignition of all fuels are low. A spark equivalent to that created by walking cross a rug and touching a ground object will ignite even the hydrocarbons fuels in the air.

Final Technical Report

CRYOPLANE

System Analysis

(Publishable Version)

The high diffusion velocity of hydrogen in air causes it to mix rapidly in confined spaces, thereby posing a greater threat in the event of an interior leak (although this same property causes hydrogen to dissipate rapidly).

Nevertheless the design of such an aircraft and its ground base must ensure the prevention any possible risk during handling and operation.

The outlook is to

- perform an example scenario of cryoplane turnaround activities etc.
 - produce example expected turnaround timing diagram
- highlight any possible differences for aircraft configurations.

4.8 Work Package 8 Transition Scenarios

Introduction

In order to achieve the aim of this work package, namely, to compile a number of transition scenarios – changing the aircraft fleet to be liquid hydrogen powered – various disciplines such as forecasting, airline business, technical matters and policy and legislative aspects need to be considered. For this task, collaboration with other work packages has been essential.

Future air traffic growth had to be forecasted, both on a regional and on a global scale. The Technical University of Berlin was responsible for the global forecasts, while regional forecasts were performed by FOI as part of the task of regional transition scenarios. The transition scenarios were established during workshops with all work package members involved.

A vital issue when studying introduction of cryoplanes was the production methods of hydrogen (work package 7), and therefore also the future availability of energy resources. Shell Hydrogen has investigated the latter. The policy and legislative aspects of hydrogen introduction in aviation have been raised by EC-JRC. A study conducted by FOI concerning optimum cruise altitude for minimum environmental impact of cryoplanes is outlined.

Global Traffic and Fleet Forecast (Task 8.2)

The market for new aircraft was based on growth and replacement. Growth scenarios were based on air transport growth estimates. Current market surveys and forecasts were reviewed for their range, structure and possible distortions reflecting, for instance, industry strategic elements. Merging several of these elements created a suitable traffic volume and flight distribution forecast. Forecasts for the short-, medium-, and long-term composition of the fleet were made. Data from these studies were used to provide the statistical framework for studying smooth transition processes in some detail (breakdown of the fleet for aircraft categories, age determining retirement, geographic region, etc.). Based on the established traffic growth, a translation was made into a forecast for the corresponding demand for aircraft, resulting in a forecast per aircraft class and region. The methodology is illustrated in Figure 8.

**Final Technical Report
CRYOPLANE
System Analysis
(Publishable Version)**

Required fleet and new aircraft were forecasted. Results are presented for a 50-year period 2000-2050.

For the years up to 2020 the aircraft manufacturers Airbus and Boeing, and engine manufacturers SNECMA and Rolls-Royce have presented detailed expectations for the future. In general, those manufacturers have assumed a rather optimistic future. Studies on forecasts of IATA and ICAO were not used because of their close a time-horizon (until 2003/2005) (ref. 8).

Based on the manufacturers' expectations two scenarios were defined. A high growth scenario, based on the average RPK (Revenue Passenger Kilometre) growth per year, per region and a low growth scenario for which some of the bias was decreased by reducing the growth percentages by 20%, to assure a considerable lower growth scenario.

From 2020 to 2050, the average growth curve was estimated by using the average growth figure for the years up to 2020. By assuming that growth will diminish over time, a growth curve can be estimated.

The results generated cover the time span 2000 until 2050, with the elements aircraft classes and regions. Data for aircraft movements, required fleet, new aircraft demand and weekly flights are presented.

**Final Technical Report
CRYOPLANE
System Analysis
(Publishable Version)**

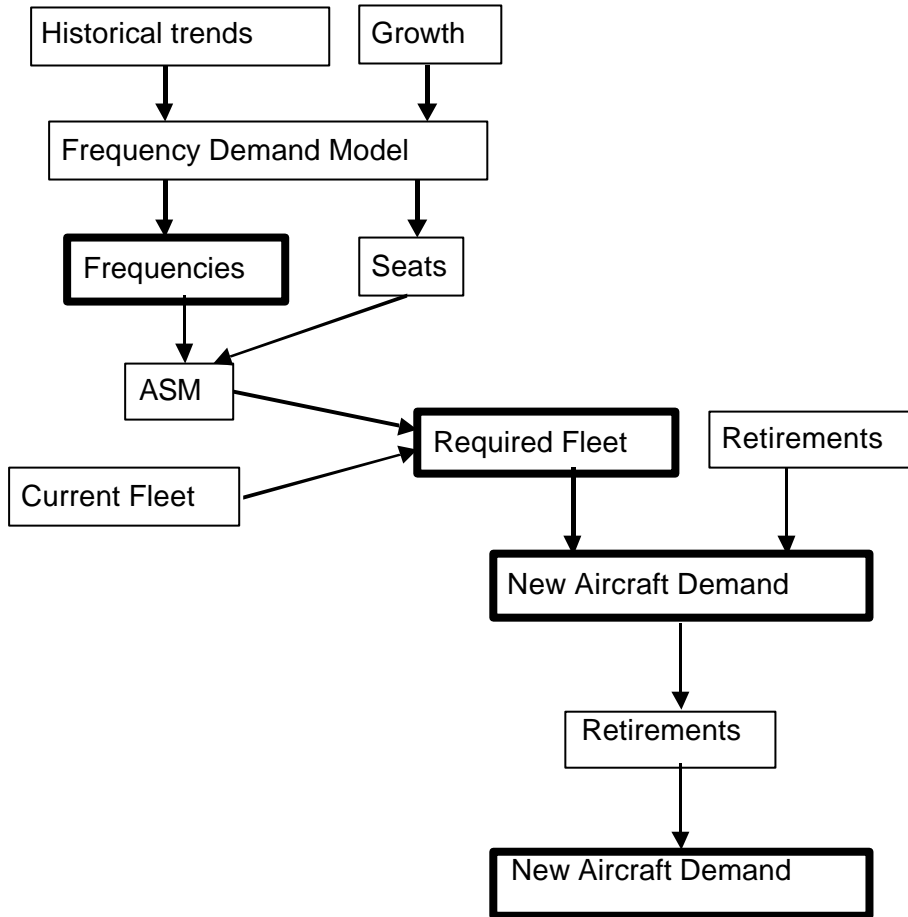

Figure 31: Methodology for Development of Air Traffic Scenarios.

According to the results, the high growth scenario indicates that in future, there will be a probable market for very large aircraft, especially in the Asia-Pacific region. According to the low growth scenario, the demand of very large aircraft will be considerably low. Most flights will be undertaken by medium-sized aircraft, like an aircraft with 141-170 seats.

Sensitivity and Optimisation (Task 8.3)

The emitted quantities of H₂O are essentially higher for cryoplanes than for aircraft powered by kerosene. In addition, the contribution to global warming from the H₂O emissions is very dependent on the altitude of discharge. Therefore, one of the main concerns regarding cryoplanes is the cruise altitude. The objectives of this task were to re-optimize and compare two equivalent medium-range aircraft – one kerosene-

Final Technical Report CRYOPLANE System Analysis (Publishable Version)

fuelled and one LH₂-fuelled – for reduced cruise altitude, from an environmental point of view.

By reducing the cruise altitude, the emission contribution to global warming is reduced, but on the other hand, the fuel consumption (increases the operation cost) and the emissions are increased due to the cruising at an altitude different from the optimum. Changed cruise altitude will also affect the configuration, and the aircraft has to be re-optimised. In general, decreased cruise altitude will increase the aircraft in size, and consequently increase the investment. Those effects are more emphasized for the cryoplane than for the conventional aircraft. Hence, lowering the cruise altitude, at the expense of increased fuel consumption and emissions, may reduce the contribution to global warming.

From this study it can be concluded that there is a potential for reducing the contribution to global warming from air traffic, by reducing the cruise altitude, especially when considering LH₂ fuelled aircraft (Figure 32). In order to achieve minimal impact on global warming from cryoplanes, and at the same time limit the increase in structure weight and fuel consumption, the results indicate that cryoplanes should cruise at an altitude of about 1-1.5 km below where conventional aircraft cruise today. On this reduced flight level, the contribution to global warming from the cryoplane is slightly less than about 20% of that of the conventional aircraft, which may be compared with the datum cruise altitude where the contribution is about 50%. Worth noticing is that the GWP decreases continuously as the cruise altitude is reduced for the cryoplane, whereas a minimum in GWP that seems to be around FL310 exists for the conventional aircraft.

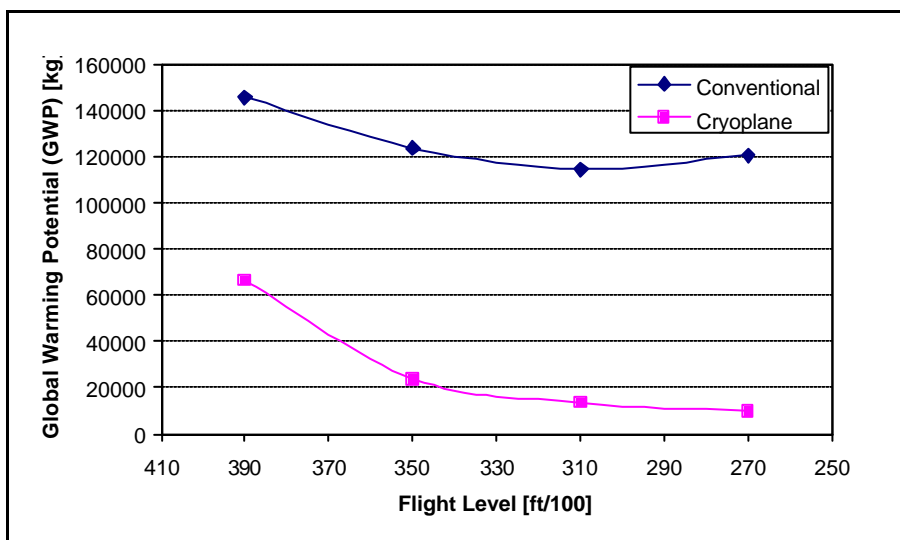

Figure 32. Effect of Cruise Altitude on GWP for Both Aircraft.

The numbers presented should be interpreted with essential caution, since they may change if the assumptions made to derive the GWP numbers change. The qualitative differences between conventional aircraft and cryoplanes are, however, expected to remain.

Final Technical Report CRYOPLANE System Analysis (Publishable Version)

Energy/Fuel Availability (Task 8.4)

This section deals with the availability of energy, particularly oil, and the potential production costs for liquid hydrogen.

USGS (US Geological Survey) has estimated that the ultimate recoverable world oil resources would be adequate to supply an expansion of 2% per annum through 2025, reaching around 125 million barrels per day (Figure 33). Thereafter a plateau could occur for around two decades before depletion would lead to a permanent decline in production. Other specialists anticipate that the plateau will be reached earlier well before 2010, with significant price rises thereafter.

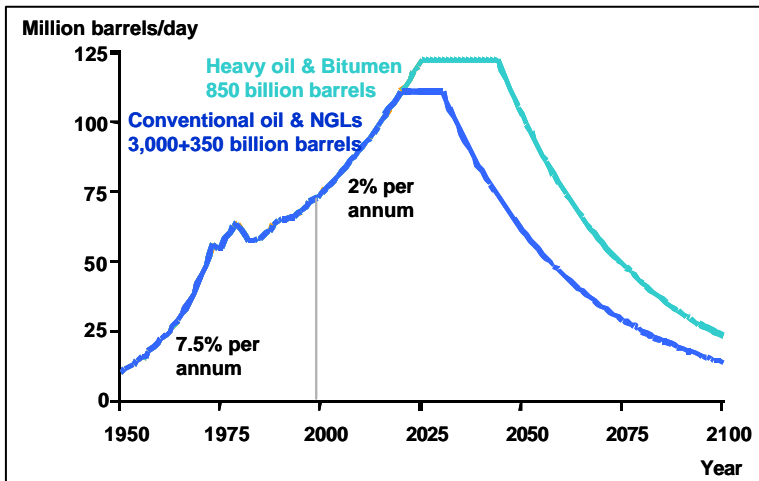

Figure 33. Potential of Liquids (Oil) Production¹.

The overall efficiency of liquid hydrogen production and delivery has been estimated to be around 40% for biomass and just over 50% for fossil fuels, with the highest efficiency from gaseous fuels at about 53%.

On this basis and assuming conservative long-term oil and gas prices, a rough outlook for delivery of liquid hydrogen can be estimated from sustainable renewable energy or from fossil fuels with all CO₂ extracted and sequestered. Biomass based liquid hydrogen could be competitive with gaseous fuel based hydrogen by 2020 if gas reaches \$4 per GJ (Giga Joule) and biomass falls to \$2 per GJ. A \$100 per tonne carbon cost penalty for gas could advance this date by around 5 years. Solar or wind based hydrogen production from electrolysis is unlikely to be competitive with biomass or fossil fuels for many decades, even for electricity production costs below \$0.04/kWh. Jet kerosene, based on a high price of \$30 per barrel crude oil and with a \$100 per tonne carbon penalty (or \$2 per GJ) would still be the lowest cost per unit of air transport energy through 2050 at around \$10 per GJ (2000 prices).

¹ NGLs (Natural Gas Liquids): Petroleum that occurs naturally as a gas in the reservoir, but as a liquid under surface conditions.

Final Technical Report CRYOPLANE System Analysis (Publishable Version)

Transition Scenarios

In addition to solving technical problems related to the airframe, propulsion system, fuel system architecture, etc., there is also a need for the evaluation of the practical feasibility of using hydrogen for civil aviation. This could be accomplished by the compilation of a number of transition scenarios, which imply changing from a conventional fleet of aircraft to a LH₂-fuelled fleet, over a certain time period. In doing so, one may either change over at a global or at a more detailed regional level. The scenarios provide information on which transition rate is feasible without burdening the airline operator too much. Furthermore, each scenario indicates the volume of LH₂ required for a realistic transition scenario, as well as the emission volumes produced according to each scenario.

Global Transition Scenarios (Task 8.5)

Based on the global traffic and fleet forecasts, three scenarios have been developed to describe the transitions from kerosene aircraft to liquid hydrogen aircraft. Results are presented per aircraft class and region. Aircraft movements, shares of traditional kerosene aircraft and liquid hydrogen aircraft have split up required fleet and new aircraft. Estimations have been made for the differences in fuel consumption and emission figures. Results are presented for a 50-year period 2000-2050.

Scenario 1 assumes a rather smoothed, stepwise approach. This scenario was selected knowing that an operation of a hydrogen fuelled aircraft will not be attractive to the market at this time due to “high” costs for hydrogen. In this scenario, the introduction of liquid hydrogen aircraft will start in 2015 in Europe for both small and medium-sized aircraft (respectively classes 2-5, <90 seats and 6-9, 90 - 220 seats). Ten years later, liquid hydrogen will be introduced on the large aircraft (classes 10-14, >220 seats) flying in Europe.

After Europe has succeeded, North America will introduce five years later hydrogen fuelled aircraft. In 2024 Asia & Pacific will introduce small and medium sized liquid hydrogen aircraft. Ten years later, large aircraft will follow. Latin America, Africa and the Middle East are the less developed regions, so Latin America and Africa & Middle East are the latest regions to introduce liquid hydrogen aircraft. In 2027 the introduction will start for both small and medium-sized aircraft, and in 2037 the large aircraft will follow.

From the introduction year on, all new-build aircraft for the region will be liquid hydrogen aircraft. This implies that the manufacturers are still producing both types of aircraft (kerosene and liquid hydrogen) until 2037.

Scenario 2 requires policy regulation from ICAO to lead to a worldwide ‘smooth’ introduction of liquid hydrogen aircraft in 2015 on both small and medium-sized aircraft (classes 2-9, ≤220 seats) and in 2025 on large aircraft (classes 10-14, >220 seats).

In this scenario it is assumed that both kerosene and liquid hydrogen aircraft are produced by the manufacturers until five years after the introduction-year, i.e. until 2020

Final Technical Report CRYOPLANE System Analysis (Publishable Version)

for small and medium-sized aircraft and 2030 for large aircraft. The production scheme of liquid hydrogen aircraft is by increments of 20% per year.

After 2040 all small and medium-sized aircraft in service will be liquid hydrogen and all large aircraft in service will be liquid hydrogen by 2050. It may be assumed that this scenario may not work without any political initiative.

Scenario 3 assumes that ICAO will make a worldwide decision in 2020 about the use of liquid hydrogen aircraft and oblige the airlines to use liquid hydrogen aircraft after 2025 for new small and medium-sized aircraft and after 2035 for new large aircraft. The ICAO-decision assures, that from the introduction year on (small+medium: 2025; large: 2035), A/C manufactures will build only liquid hydrogen aircraft.

The following table gives the summary of the results of the three scenarios. As can be concluded from those results, political pressure is needed to assure a 100% liquid hydrogen fleet in 2050. Scenario 1, which assumes a stepwise region by region approach for introduction of cryoplanes and only stimulating policies without binding pressures also comes quite closely to the 100% replacement. The introduction year however is quite soon and no extensive testing of a prototype will be possible. This scenario is the most market driven scenario: no need of political initiatives may be taken into account and no global introduction at once is expected.

		100% year or 2050 percentage			
		Scenario 1 High	Scenario 1 Low	Scenario 2 High	Scenario 3 High
Small aircraft	World	94%	93%	2040	94%
	Europe	2043	2042	2040	96%
Medium aircraft	World	97%	97%	2040	95%
	Europe	2044	2044	2040	96%
Large aircraft	World	75%	73%	2050	65%
	Europe	93%	92%	2050	64%

Figure 34: Indication of Year When 100% CRYOPLANES (if earlier than 2050) is Achieved, or the Percentages in 2050.

Using detailed analysis of aircraft fleet demand, figures on aircraft movements and weekly number of flights for each scenario, the fuel consumption and emissions were calculated on a weekly basis. From the NO_x emission curves it could be concluded that whatever scenario might apply, NO_x emission volumes as of today cannot, probably, be achieved before a 50 years time span. In the meantime NO_x emissions will increase from today's level by about factor 2 (Scenario 1) to 4 (continuing use of kerosene) caused by traffic growth.

Final Technical Report CRYOPLANE System Analysis (Publishable Version)

Case Study: Transition in a Leading Region (Sweden) (Task 8.6)

In this study SAS's share of the Swedish domestic air traffic is investigated. According to two different assumed traffic growth curves – one low-growth (“authority forecast”) and one high-growth (“industry forecast”) – and through consideration of the airline's approach to fleet development, two different conventional fleet developments were assessed. For each traffic growth scenario, respectively, two scenarios with different assumptions have been developed: assuming that all new aircraft introduced in 2015 and 2025, respectively, and after are LH₂ fuelled. Having defined the scenarios, the emissions related to these scenarios were estimated, and presented in relation to emissions of the conventional fleet. The fuel sources and infrastructure changes needed at Stockholm-Arlanda airport, and for distribution of the LH₂ were identified and assessed.

The results indicate that, according to the traffic growth scenarios assumed for these studies, the number of passengers would increase three to four times by 2050. During the same time period the number of movements will increase, but by less than the number of passengers, due to the larger aircraft types commencing on the domestic market. Depending on the scenario, the number of movements will increase by 70-90%. Hence, it may be concluded that an essential increase in airport capacity, at all airports, is required to cope with the increasing traffic demand. In all scenarios it is reasonable to change to a fleet solely powered with liquid hydrogen by 2050.

Regarding the changes needed at the airport when using hydrogen, there are a number of measures that need to be taken to ensure that the safety level at the airport is preserved. In order to avoid a fire hazard, spark ignition engines should be avoided. A very pleasing and feasible solution would be to power all airport vehicles by fuel cells driven by hydrogen. The overall airport layout and procedures should not change, and the aircraft can be refuelled at gate positions exactly like conventionally fuelled aircraft. Largely, the required changes have to do with refuelling procedures. Since hydrogen is a cryogenic fuel, what really needs to be changed is the interface between the fuel supplies and the aircraft fuel tanks, as well as most of, if not all, the fuel system components. However, the intention is that hydrogen should be distributed in a way similar and parallel to that of kerosene. Thus, from an airport infrastructure point of view, it certainly is feasible to change to hydrogen use. No significant changes on turn-around times are expected with cryoplanes.

Taking the local conditions, with respect to the availability of energy, it would be possible to change from kerosene to LH₂ as fuel for all civil aviation refuelling in Sweden. However, the development and extension of renewable energy sources parallel to the introduction of cryoplanes is important, to make sure that no or very little fossil-based energy sources are used for the LH₂ production. If electrolysis of water or gasification of biomass would be used for the LH₂ production, considerable amounts of electrical energy and biomass sources, respectively, would be required, but not unreasonably much.

It is worth mentioning that the cost penalty of changing the fleet to use LH₂ is not thoroughly assessed in this task. In order to fully cover the implications with respect

Final Technical Report CRYOPLANE System Analysis (Publishable Version)

to costs of changing the fleet, several aspects comprising difficulties need to be addressed. As the scenarios stretch several decades ahead and as some technologies need further development, it is crucial to assess the costs of all new facilities. Moreover, to make a fair comparison between cryoplanes and conventional aircraft, future price trends of kerosene needs to be taken into account. The price of kerosene will rise in the future, both due to dwindling oil resources and possibly due to future taxation (e.g. CO₂-tax). Besides, to fully understand the cost implications of introducing hydrogen in aviation, other modes of transportation as well as the power industry, should be considered. Possible co-ordination gains could have a significant effect on the cost penalty. A study addressing all these issues is beyond the scope of this task.

Policy and Legislative Aspects of Transition (Task 8.7)

This study aimed to review the current situation with regard to the political context and regulatory framework, in which the transition towards the mainstream use of hydrogen in civil aviation could occur; it also aimed to identify the key policy drivers of such a transition and highlight the need for concrete political and legislative action to ease the introduction of hydrogen as aviation fuel.

The main policy drivers for change in the energy and transport sector and technology mix are the worldwide need to respond to a perceived threat by man-made climate forcing, and the need of western economies to ensure the security of their energy supply. Both of these requirements pose significant strain on key economic sectors such as aviation, being vulnerable to disruptions of the energy supply chain.

Priorities for policy action to support the transition towards hydrogen-fuelled aviation include getting the price of aviation fuel right, and, thus, removing indirect and direct subsidies and tax breaks currently supporting kerosene.

In order to facilitate the introduction of hydrogen use in aviation the following issues are important to address:

- The identification of potential technological and financial synergies among different market sectors, which could reduce the economic burden of the introduction of new energy carriers such as hydrogen (e.g. through the shared use of infrastructure).
- Environmental policies (including energy (fuel) taxation), which could facilitate the transition. Such policies should focus on setting the emission standards based on integrated assessment of the impact state-of-the-art energy technologies and fuel would have on public health and environment. As well as getting the market price of fuel right (i.e. internalise externalities).
- The appropriate setting for a technological initiative uniting the major market actors in the aeronautics and liquid fuel/gas industries.

Conclusions

Assuming demand growth of 2% per annum and the ultimately recoverable world oil resources the market could meet this expansion until 2025. Thereafter a plateau could occur for around two decades before depletion would lead to a permanent de-

Final Technical Report

CRYOPLANE

System Analysis

(Publishable Version)

cline in production. But kerosene is likely to remain the lowest cost per unit of air transport energy for a number of decades. This points out that cryoplanes will only be able to enter market of civil aviation forced by political measures.

Depending on the scenario in the global approach, the world-wide fleet may or may not be solely powered by liquid hydrogen in 2050. Scenario 1, which assumes a stepwise region by region approach for introduction of cryoplanes and only stimulating policies without binding pressures, comes quite closely to the 100% replacement by 2050. The introduction year, however, is quite soon and no extensive testing of a prototype will be possible. Although the introduction year for scenario 3 is quite late, most of the small and medium sized aircraft fleet has been replaced in 2050. In this scenario ICAO must play a very active worldwide role in pressing the airlines to fly with liquid hydrogen aircraft.

With regard to the regional scenarios it is, with the assumptions made in this study, reasonable to change to a fleet powered with liquid hydrogen, solely, by 2050. To sum up concerning the airport infrastructure, the demand for new facilities for conversion to operation of cryoplanes is evident; however, the changes required at the airport seem to be practicable and no major obstacles are expected. Considering the local conditions, with respect to the availability of energy, it would be reasonable to change from kerosene to LH₂ as fuel for all civil aviation refuelling in Sweden. However, the development and extension of renewable energy sources parallel to the introduction of cryoplanes, is important to make sure that no or very little fossil-based energy sources are used for the LH₂ production.

Concerning the cruise altitude as a means of reducing environmental impact, it can be concluded that there is a potential for reducing the contribution to global warming from air traffic, by lowering the cruise altitude, especially when considering LH₂ fuelled aircraft. In order to achieve minimal impact on global warming from cryoplanes, and at the same time limit the increase in structure weight and fuel consumption, the results indicate that cryoplanes should cruise at an altitude of about 1-1.5 km below where conventional aircraft cruise today.

In order to facilitate the introduction of hydrogen use in aviation the following policy and legislative aspects are important to address:

- The identification of potential technological and financial synergies among different market sectors, which could reduce the economic burden of the introduction of new energy carriers such as hydrogen (e.g. through the shared use of infrastructure).
- Environmental policies (including energy (fuel) taxation), which could facilitate the transition. Such policies should focus on setting the emission standards based on integrated assessment of the impact state-of-the-art energy technologies and fuel would have on public health and environment. As well as getting the market price of fuel right (i.e. internalize externalities).
- The appropriate setting for a technological initiative uniting the major market actors in the aeronautics and liquid fuel/gas industries.

Final Technical Report CRYOPLANE System Analysis (Publishable Version)

4.9 Work Package 9 Trade-off Study: Slush

Based upon an extensive review of known slush characteristics and advanced production methods, overall consequences on aircraft design, performance and economics were assessed. Conclusions are:

The higher density of a practical slush (appr. – 260°C, 50% solid in terms of mass) allows a 20% smaller tank volume, with **beneficial consequences** (enhanced by snowballing effects) in respect to

- Fuselage length/volume,
- Wetted area,
- Aerodynamic efficiency
- Operating weight empty,
- Engine thrust,
- Fuel consumption
- Max take-off weight.

Equally, the higher heat capacity allows reducing the insulation for the same time on ground without out-gassing.

Technical advantages listed above would offer a noticeable benefit in terms of Direct Operating Cost. However, the cost to produce slush is higher than to produce LH2; the difference is estimated to be in the order of 8 – 17 %, fuel price correspondingly higher. In consequence, the net effect of using slush in place of LH2 during this study was not clear identifiable in respect of Direct Operating Cost. Future studies may take SH2 in further consideration as an alternative to LH2.

5 Results and Conclusions

Based upon results achieved in the project (main points summarized above), the following general conclusions can be drawn:

- **Use of Liquid Hydrogen to fuel aircraft for commercial airline service is technically feasible. However, there is a need for much more R&D work to make the technology ready for routine commercial operation.**
- **There is some indication that use of Liquid Hydrogen, produced on the basis of renewable energy, has the potential to reduce the impact of civil aviation upon the atmosphere, both locally and globally (greenhouse effect). Flight research into contrail characteristics is recommended.**
- **Hydrogen fuelled aircraft will be at least as safe as kerosene aircraft. Large-scale tests are recommended for the most critical case, which can be envisaged, i.e. a tank is hit by some high-energy projectile (e.g. Un-contained engine failure).**

Final Technical Report CRYOPLANE System Analysis (Publishable Version)

- **The use of slush in place of liquid hydrogen does not offer a convincing advantage to justify major dedicated efforts.**
- **Fossil resources (oil conventional and unconventional) can cover the needs of aviation for kerosene over the next half-century. The cost of producing hydrogen from a renewable energy basis will be higher than the cost of producing kerosene on a fossil basis for many decades to come.**
- **Transition from kerosene to hydrogen can be initiated in the mid term only by some drastic political event or action, e.g. political measures to reduce aviation's CO2 emissions. A scenario with the transition starting in some defined "leading region", e.g. in Scandinavia, has been studied.**
- **One single time scale for the transition cannot be given, and depends upon timing and force of political actions. A long term R&T program to prepare for transition must take this into account.**

Conclusions

Results achieved confirm the feasibility and the environmental benefits of using liquid hydrogen as an aviation fuel in all categories of commercial aircraft. Results hence are relevant for all sectors of civil aviation, for aircraft/ engine/ equipment suppliers, airlines, and airports.

Under today's economic conditions, hydrogen is not yet economically competitive.

Transition scenarios have shown that aircraft using liquid hydrogen may first enter commercial operation in about 2015.

Estimation on the development production costs of the kerosene on one side and on the other H2 has shown that we could expect an equivalent price in 2040.

If efforts to limit greenhouse gas emissions are effectively stalled for a long time by some political initiative (like CO2 tax etc.), the date may well shift by many years.

Overall technical challenges are understood, known design principles can be applied in for new components. Of course, there is a need for further R&D work to achieve operational readiness.

6 Acknowledgements

Authors: All work package leaders contributed according to their work package to this report.

Final Technical Report CRYOPLANE System Analysis (Publishable Version)

WP1 Project Coordination:	Andreas Westenberger (Airbus D. GmbH)
WP2 Aircraft Configuration:	Prof. van Holten (TU Delft)
WP3 Systems and Components:	Mr. Allidieres (Air Liquide)
WP4 Propulsion:	Prof. Singh (Cranfield University)
WP5 Safety:	Dr. Sarigiannis (JRC Ispra)
WP6 Environmental Compatibility:	Prof. Zerefos (Aristotle Univ. Thessabniky)
WP7 Fuel Sources and Infrastructure:	Prof. Hapke (Techn. Univ. Hbg. Harburg)
WP8 Transition Scenarios:	Dr. Westerberg (FOI)
WP9 Trade-off: Slush:	Dr. Brunnhofer (Magna Styr)

Finally I would like to thank all authors of all 36 partner companies for their very comprehensive and competent contribution to this project.

7 Glossary

APU	Auxiliary Power Unit
BP	Boost Pressure
CO	Carbon Monoxide
DOC	Direct Operating Costs
EEC	Electronic Engine Controller
FL	Flight Level
FSS	Fuel Supply System
GH ₂	Gaseous Hydrogen
GJ	Giga Joule
GWP	Global Warming Potential
HP	High Pressure
IATA	International Air Transport Association
ICAO	International Civil Aviation Organization
LP	Low Pressure
LPP	Lean Premix Prevaporized
MTOW	Maximum Take-Off Weight
NO _y	reactive nitrogen compounds, incl. nitric acid
NPSP	Net Positive Suction Pressure
OWE	Operating Weight Empty
Pinj	Injection Pressure
RF	radiative forcing
RQL	Rich burn-Quick quench-Lean burn
SEC	Specific Energy Consumption
SFC	Specific Fuel Consumption
TET	Turbine Entering Temperature
Tinj	Injection Temperature
UHC	Unburned HydroCarbons
VLLR	Very Large Long Range Aircraft

**Final Technical Report
CRYOPLANE
System Analysis
(Publishable Version)**

8 References

The content of this report is based on the results of the technical reports, which were produced by the partners during the whole period of this project.

Specific References:

1. ICAO Annex 16 Environmental Protection VOL II, Aircraft Engines Emissions. and ICAO Engine Exhaust Emissions Data Bank http://www.dera.gov.uk/html/te/combustion/t&e_aircraft_engine_exhaust_emissions_data_bank.htm
2. Dahl G., and Suttrop, F. (2002) TTR 4.4-5A The Micromix Hydrogen Combustor Technology – System analysis, 5th Framework program of the European Communities, Contract No. G4RD-CT-2000-00192
3. Dahl G., and Suttrop, F, 1999: Engine control and low- NO_x combustion for hydrogen fuelled aircraft gas turbines, Int. J. Hydrogen Energy, 23, 695-704.
4. Christos Zerefos et al. (2002) WFR-6. Environmental Compatibility, Liquid hydrogen fuelled aircraft – System analysis, 5th Framework program of the European Communities, Contract No. G4RD-CT-2000-00192
5. Intergovernmental Panel on Climate Change (IPCC), Aviation and the Global Atmosphere. *Cambridge University Press, Cambridge, UK*, 1999.
6. Marquart, S., R. Sausen, M. Ponater, and V. Grewe, 2001: Estimate of the climate impact of cryoplanes, *Aerosp. Sci. Techn.*, 5, 73-84.)
7. Allidiere, Laurent 2002 TFR7.4 Review of liquefaction processes, Liquid hydrogen fuelled aircraft – System analysis, 5th Framework program of the European Communities, Contract No. G4RD-CT-2000-00192
8. Hüttig G., Kappers A. and Essers I. (2001) *Global Transition Scenarios*, Task Final Report 8.5-1, CRYOPLANE Project.